

Synthesis of Poly methacryloyloxyethyl trimethyl Ammonium Chloride and their Anti Bacterial Activity

GENG SU, YA-JIE JIANG, HONG-BIN JU, YA-KUI WANG AND TAO GENG*

*China Research Institute of Daily Chemical Industry, Taiyuan,
Shanxi Province 030001, China*

ABSTRACT

Two kinds of poly quaternary ammonium salts (PQAS) namely PDMC (poly (methacryloyloxyethyl trimethyl ammonium chloride)), CPAM (methacryloyloxyethyl trimethyl ammonium chloride / acrylamide copolymer) were prepared. The chemical structures of the PQAS were characterized by Fourier transform infrared (FT-IR), nuclear magnetic resonance (¹H NMR) spectrum, thermogravimetric analysis (TGA), and scanning electron microscope (SEM). The antibacterial activity of PQAS against three kinds of bacteria and one kind of fungus, was evaluated by the method described in QB/T 2738-2012. Antibacterial tests showed that the antibacterial activity increased with the increase of cationicity and molecular weight on PQAS. It shows the antimicrobial activity for different bacteria strain follow this order: Escherichia coli (E. coli) > Staphylococcus aureus (S. A.) > Shigella > Monilia albican (M. A.).

KEYWORDS: *Methacryloyloxyethyl trimethyl ammonium chloride; Acrylamide; poly quaternary ammonium salts; Antibacterial activity.*

INTRODUCTION

The viral microorganisms pose serious threats to human life and property safety, such as the outbreak of SARS virus, Ebola virus, avian influenza virus, anthracnose, mad cow disease, and pathogenic E. coli in recent years. The hazards of these viruses are caused by microorganisms. These microorganisms rapidly

multiply under certain external conditions and spread through mutual contact, thus affecting human health. Antibacterial agents have important significance in reducing disease transmission, protecting human health, and improving human living environment.^[1]

Quaternary ammonium salts (QAS) are the most commonly used antimicrobial agents.^[2]

Compared with poly quaternary ammonium salts (PQAS), they have the following disadvantages: high toxicity, high skin irritation, hard to degrade, and easy enrichment on the surface of the human body, resulting in human skin lesions.^[3-4] In the nature, bacterial surfaces are usually negatively charged,^[5] the higher antibacterial activity of PQAS has been interpreted as follows: the net positive charge of PQAS and the net negative charge of bacterial cell membranes drive the initial attraction of the PQAS to the cell surface. After binding to the negatively charged phospholipid, hydrophobic moieties on the PQAS interact with the inner hydrophobic core of the bacterial membrane leading to a disruption of the cytoplasmic membrane to release K^+ and other constituents which cause cell death.^[6]

The antimicrobial activity of PQAS is often affected by many factors such as molecular weight, type of counter anion, charge density, alkyl chain length and steric hindrance, hydrophilic-hydrophobic balance, and the bacterial spices.^[7-8] Homopolymers of quaternary ammonium salts exhibits an antibacterial effect better than the corresponding monomers.^[9-10] Ikeda and co-workers studied the antibacterial activity of acrylamide with an acrylate copolymer with a biguanide structure and an acrylate homopolymer of a biguanide structure. The test found that when the molecular weight is between 50,000 and 120,000 the polymer has the best antibacterial activity.^[11] Dizman and co-workers synthesized a polymer with a side chain quaternary ammonium salt antibacterial group based on polyacrylate as the main chain.^[12] It has been found that a quaternary ammonium salt with a long-chain alkyl group

has superior antibacterial properties. Lu and co-workers prepared a methacryloxyethyl-dimethyl dodecyl ammonium bromide/acrylamide copolymer and found that the higher the charge density, the better the antibacterial property.^[13] To this end, acrylamide is used to adjust the charge density and polymer molecular weight because it is a water-soluble and does not exhibit any antibacterial activity by itself.

The different structures of bacteria and fungi lead to differences in the antimicrobial activity of PQAS against bacteria and fungi. Therefore, the molecular weight and charge density of PQAS play a crucial role in studying fungi and bacteria. In this article, we picked acrylamide (AM) and methacryloxyethyl trimethyl ammonium chloride (DMC) to prepare poly (methacryloxyethyl trimethyl ammonium chloride) (PDMC), methacryloxyethyl trimethyl ammonium chloride / acrylamide copolymer (CPAM) by aqueous solution polymerization. Its molecular weight and cationicity was adjusted to explore its antibacterial activity against three kinds of bacteria and one kind of fungus.

EXPERIMENTAL

Materials

Methacryloxyethyl trimethyl ammonium chloride (DMC, 79.8%), was purchased from Wanduoxin Chemical Co. Ltd., (Shandong China); acrylamide (AM, 98%) was purchased from Xinyong Biochemical Co. Ltd., (Zhejiang China); potassium persulfate ($K_2S_2O_8$), CP, was obtained from Tianda Chemical Experimental Factory (Tianjin China); sodium ethylenediamine tetraacetate (Na_4EDTA), potassium chromate (K_2CrO_4) and silver nitrate ($AgNO_3$), CP, were purchased from China Pharmaceutical Group Chemical Reagent Company (Shanghai China); Bacteria strain: *Staphylococcus aureus* (ATCC6538) (S. A.) and

Escherichia coli (ATCC8099) (*E. coli*) were purchased from Microbiological Culture Collection Center, China Academic of Science. *Shigella* and *Monilia albican* (CGMCC) (*M. A.*) were purchase from China General Microbiological Culture Collection Center. Nutrient agar was purchased from Beijing Land Bridge Technology Co., Ltd. Potassium phosphate monobasic and disodium hydrogen phosphate were from Tianjin Kermel Reagents Development Centre (purity > 99.5%).

Synthesis of DMC homopolymers and AM/DMC copolymers

DMC was polymerized by a free radical polymerization as shown in Figure 1. A series of PDMC with various molecular weight was prepared as follows. A certain amount of DMC monomers was made aqueous solution in four-necked flask equipped with a condenser, a magnetic stirrer, a nitrogen inlet and a nitrogen outlet. After the removal of oxygen in the flask by flowing nitrogen for 0.5 h, to which a desired amount of $K_2S_2O_8$ (0.12g, 0.44×10^{-3} mol) and Na_4EDTA (0.01g, 0.2×10^{-4} mol) was added, and then the reactants were heated to 68 °C. The mixture was

stirred under flowing nitrogen for 6 h. Different molecular weight PDMCs were adjusted by the concentration of DMC. The obtained PDMC was precipitated in acetone and then vacuum dried at 50 °C for 12 hours. A white solid PDMC was obtained as the final product. In order to investigate the importance of cationicity to antibacterial activity, we prepared a series of CPAM with different cationicity by copolymerization of AM and DMC. CPAM was polymerized by a free radical polymerization as shown in Figure 2. The specific preparation method is similar the preparation method of DMC homopolymers.

Characterization Methods

FTIR spectra were collected on a Vertex70 Fourier transform infrared spectrosocopy (Bruker) using KBr pellets.

1H NMR spectrum was performed on a Bruker nuclear magnetic resonance instrument (400 MHz) using deuterated water (D_2O) as solvent.

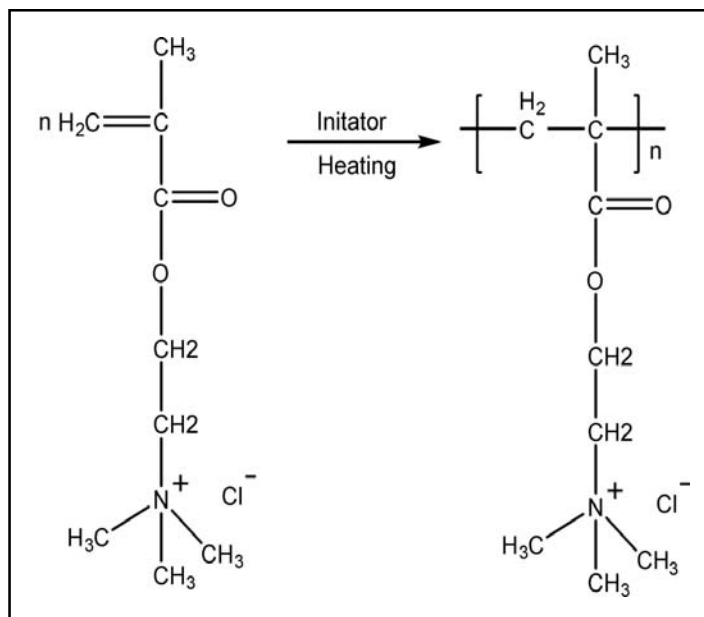

Fig. 1. Synthesis of DMC homopolymers

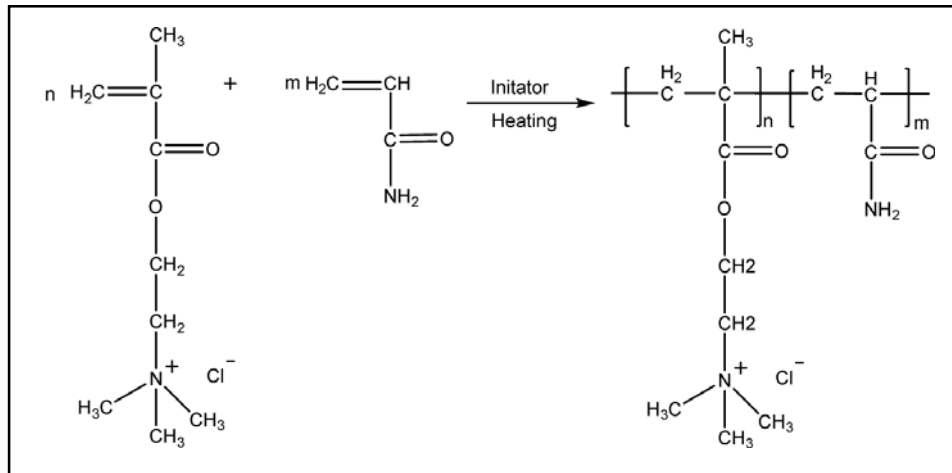

Fig. 2. Synthesis of AM/DMC copolymers

The intrinsic viscosities $[\eta]$ of polymers were determined according to GB/T 12005.1-1989. The intrinsic viscosities $[\eta]$ of polymers was measured using ubbelohde viscometer in 1N sodium chloride solution at $(30 \pm 1)^\circ\text{C}$.^[14] Polymer molecular weight is calculated according to equation (1):

$$Mr = 802 \cdot [\eta]^{1.25} \quad (1)$$

Dissolving the copolymer in water, using K_2CrO_4 as an indicator, titrating with AgNO_3 standard solution, determining the Cl^- content, which is the content of DMC in the copolymer as the cationicity of CPAM.

The samples were heated from 10°C to 800°C in nitrogen and the thermal stability analysis of samples was conducted using thermogravimetric analyzer (HTG-3).

The morphologies of the samples were analyzed with a KYKY-2800B scanning electron microscope.

Antibacterial Properties

The antimicrobial properties of PDMC and CPAM solutions were evaluated by the method recommended in QB/T 2738-2012. The antibacterial properties against three kinds of bacteria: Escherichia coli (E. coli),

Staphylococcus aureus (S. A.) and Shigella, and one kind of fungus: Monilia albican (M. A.). The operation method is as follows:

Prepared test sample solutions, phosphate buffered saline (PBS) and nutrient agar medium. PBS and nutrient agar medium were sterilized by pressure steam at the temperature of 121°C for 20 min and their pH was adjusted to 7.2–7.4. All tubes and transfer pipettes were sterilized by pressure steam at 125°C for 20 min. The samples of bacteria (E. coli, S. A., Shigella and M. A.) were diluted to a concentration of 1×10^4 – 9×10^4 CFU/mL by PBS. The bacterial sample (0.1 mL) and the sample solution (5.0 mL) were mixed by a vortex mixer for 2 min, and then 0.5 mL of the mixed solution was further mixed with 4.5 mL of PBS with stirring. After 10 min, a mixture of 1.0 mL of the bacterial sample solution and PBS was inoculated onto the sterile disposable petri dish. The nutrient agar medium (15 mL, 45°C) was then added to the Petri dish. After incubating the culture dishes at 37°C for 48 h, colony forming units (CFU) were counted. Control experiments were also included in the experiment, which did not contain PDMC and CPAM solutions. All the bacteriostatic tests were repeated three times for each sample. The bacteriostatic ability was evaluated by percentage of experiment results (CFU_{exp}) compared with blank controlled results (CFU_{con}) (Equation (2)).^[15]

RESULTS AND DISCUSSION

Preparation of PDMC and CPAM

As known the cationicity and molecular weight of antibacterial polymers have great influence

on antimicrobial activity.^[16-17] In this paper, a series of cationic PDMC were synthesized (as shown in Table 1). The molecular weight of PDMC increased from 0.94×10^5 to 3.79×10^5 with increasing the DMC content from 15 to

$$\text{Bacteriostatic percentage (B\%)} = \frac{\text{CFU}_{\text{con}} - \text{CFU}_{\text{exp}}}{\text{CFU}_{\text{exp}}} \times 100\% \quad (2)$$

35 %. It indicated that the DMC content had strong influence on molecular weight. This is because the more DMC content in the solution, the easier it is to polymerize linear macromolecules PDMC in solution, and thus the molecular weight of the PDMC increases.

Table 2 gave the information about the impact of the monomer ratio on the molecular weight. It can be seen from CPAM1, CPAM2, CPAM3 and

CPAM4 of Table 2, the molecular weight of CPAM was approximately 6.37×10^5 when the monomer feed ratio was 5.88, and it declined to 1.89×10^5 with the ratio decreased to 0.97. This was primarily due to that the reactivity of DMC was weaker than that of AM under the same conditions, hence with the concentration of DMC increasing, reaction activity of polymerization decreased. At the same time, with the decrease the monomer feed ratio, increasing the content of DMC in

TABLE 1. Polymers Formed by DMC with Different Mass Concentrations

Sample	Mass Fraction of DMC (%)	Monomer ratio (mol/mol) AM/DMC	Cationicity (%)	Molecular Weight
PDMC1	15	0	100%	0.94×10^5
PDMC2	20	0	100%	1.54×10^5
PDMC3	25	0	100%	2.04×10^5
PDMC4	30	0	100%	2.89×10^5
PDMC5	35	0	100%	3.79×10^5

TABLE 2. Copolymer CPAM series synthesized with various monomer ratio

Sample	Mass Fraction of DMC and AM (%)	Monomer ratio (mol/mol) AM/DMC	Cationicity (%)	Molecular Weight
CPAM1	15	5.88	14.2	6.37×10^5
CPAM2	15	2.94	25	4.71×10^5
CPAM3	15	1.47	40	2.76×10^5
CPAM4	15	0.97	50	1.89×10^5
CPAM5	20	0.97	50	4.64×10^5

the CPAM, thus enhancing the cationicity of the CPAM. In order to observe the effect of cationicity on antibacterial properties, CPAM5 was synthesized and its molecular weight was around same as CPAM2.

Fig. 3 shows the FT-IR spectrum of AM, DMC, PDMC and CPAM. For AM: FT-IR (cm^{-1}): 3500-3180 ($-\text{NH}_2$), 1674 ($\text{C}=\text{O}$), 1605 ($-\text{C}-\text{N}$); DMC:

3017-2956, 1470 ($=\text{C}-\text{H}$), 1712 ($\text{C}=\text{O}$), 1624 ($-\text{C}-\text{N}$), 1293-1194 ($\text{C}-\text{O}-\text{C}$), 954 ($-\text{N}(\text{CH}_3)_3$); PDMC: 3017-2970, and 1470 ($=\text{C}-\text{H}$) weaker than DMC, 1618 ($-\text{C}-\text{N}$), 943 ($-\text{N}(\text{CH}_3)_3$), 1712 ($\text{C}=\text{O}$), 1293-1194 ($\text{C}-\text{O}-\text{C}$) and CPAM: 3602-3256 (NH_2), 1644 ($\text{C}=\text{O}$), 2959-2987 (long chain, $-\text{CH}_3$, CH_2), 1566 ($-\text{C}-\text{N}$), 1249-1031 ($\text{C}-\text{O}-\text{C}$), 944 ($-\text{N}(\text{CH}_3)_3$).

FTIR spectra analysis

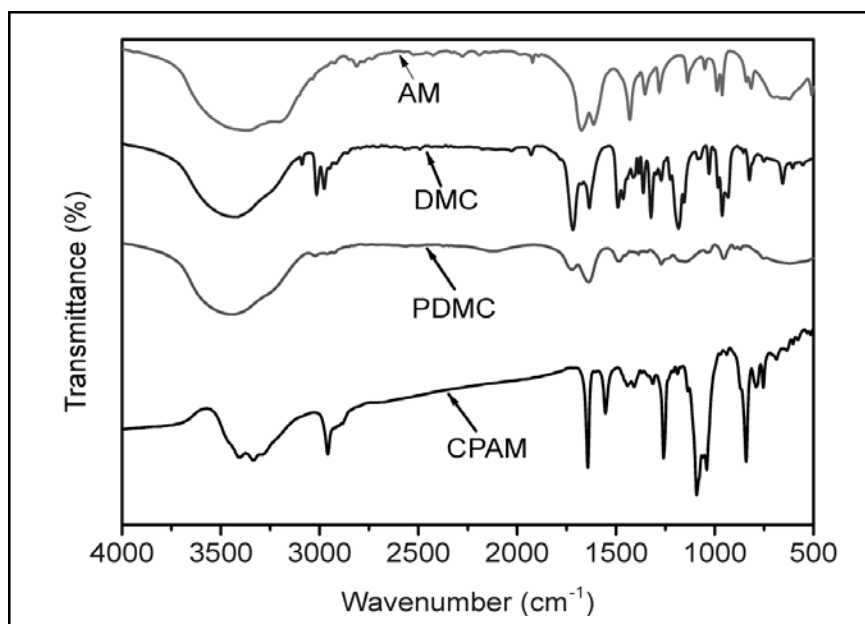

Fig. 3. FTIR spectra of monomers: AM, DMC and samples: PDMC, CPAM

$^1\text{H-NMR}$ spectra analysis

Fig. 4 displays the $^1\text{H-NMR}$ spectrum of AM, DMC, PDMC and CPAM, $^1\text{H-NMR}$ (δ , ppm) analysis of AM: 6.25 (m, $\text{CH}_2=\text{CH}-$), 5.7 (q, $\text{CH}_2=\text{CH}-$) and DMC: 6.31-5.75 ($\text{CH}_2=\text{C}$), 4.5 ($-\text{O}-\text{CH}_2-$), 3.65 ($-\text{N}-\text{CH}_2-$), 3.05 (s, $-\text{N}(\text{CH}_3)_3$), 1.98 (s, $=\text{C}-\text{CH}_3$). $^1\text{H-NMR}$ (δ , ppm) analysis of PDMC:

4.45 ($-\text{O}-\text{CH}_2-$), 3.65 ($-\text{N}-\text{CH}_2-$), 3.05 (s, $-\text{N}(\text{CH}_3)_3$), 1.91 (s, $-\text{CH}_2-\text{C}-$), 0.95 (s, $-\text{C}-\text{CH}_3$) and CPAM: 4.45 ($-\text{O}-\text{CH}_2-$), 3.65 ($-\text{N}-\text{CH}_2-$), 3.05 (s, $-\text{N}(\text{CH}_3)_3$), 2.02 ($-\text{CH}-\text{CH}_2-$), 1.59 ($-\text{CH}_2-\text{C}-$), 1.5 ($-\text{CH}_2-\text{CH}-$), 1.0 (s, $-\text{C}-\text{CH}_3$). Based on the FT-IR and $^1\text{H NMR}$ spectrum, it can be demonstrated that polymer PDMC and CPAM were prepared successfully.

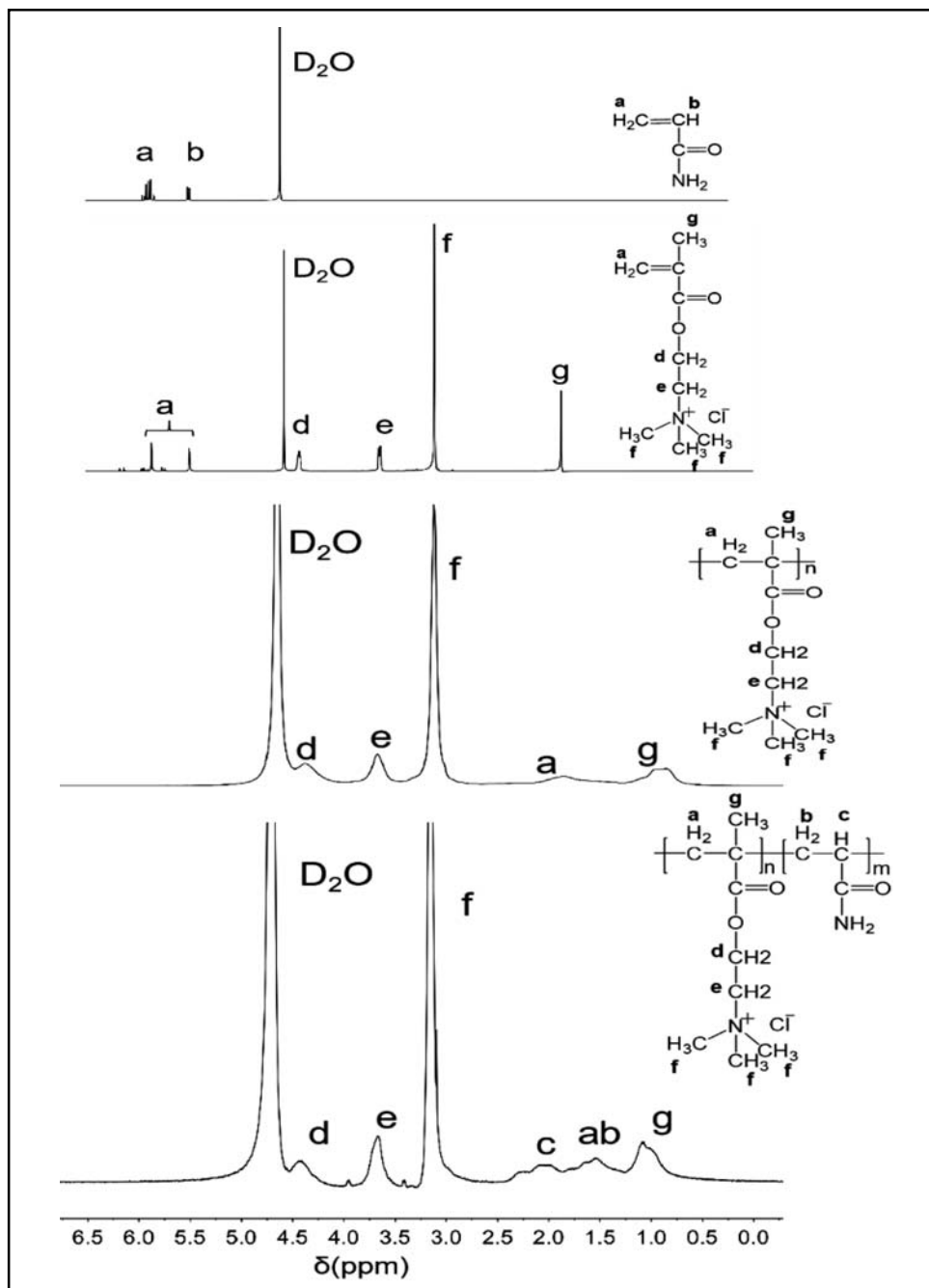

Fig. 4. ¹H NMR spectra of monomers: AM, DMC and samples: PDMC, CPAM

TGA analysis

The thermal stability of PDMC and CPAM was studied by TGA, and the applicable temperature range was received. Figure 5 gave information on degradation extent of PDMC and CPAM with increasing heating temperature. Seen from the Fig. 5, PDMC and CPAM mainly has three weight loss stages. At first stage, with the temperature rose to roughly 235°C, the amounts of both weights were decreased from 100 to 93% and it was the process of water losing in PDMC and CPAM. The temperatures between approximately 235 and 320°C witnessed a dramatic decline in weight of PDMC and CPAM reaching some 38 and 47% of total respectively, this was ascribed to the decomposition of acrylamide group -CO-NH-

in AM and C=O, quaternary ammonium -N(CH₃)₃ in DMC. [18] In the third stage, the PDMC loses 38% weight and the rate of weight loss is slow, which may be caused by the short molecular chain in the PDMC. However, CPAM has a weight loss of 31% and a sharp weight loss between 360°C and 440°C, which was result from the length of molecular chain. [19-20] All in all, PQAS has good thermal stability at ordinary temperature.

SEM analysis

The Fig. 6 illustrates the SEM images of PDMC, CPAM and laboratory self-synthesizing poly acrylamide (PAM), thus three different surface morphology were observed. Compared to the PAM surface, the CPAM surface appears rougher, the same as chewing gum surface. It could be seen that the structure of PDMC was

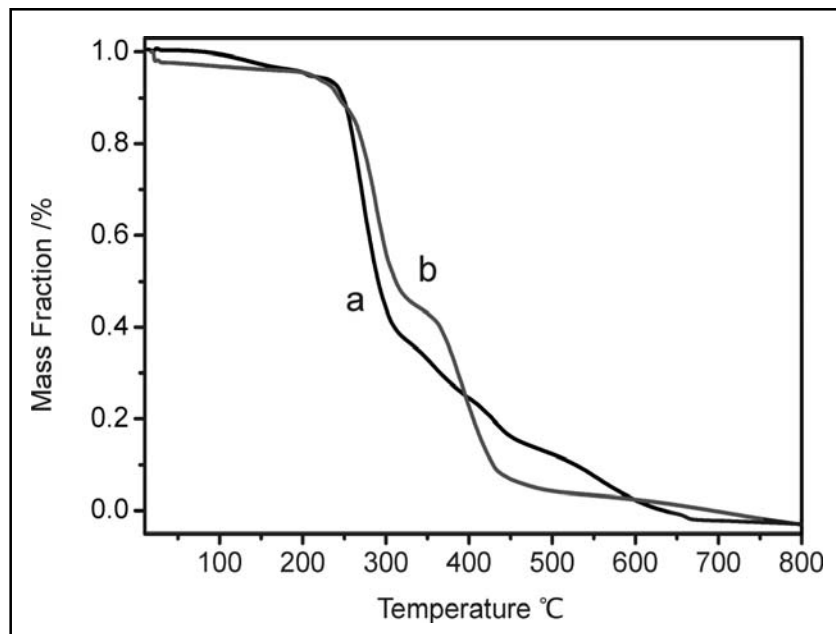

Fig. 5. TGA spectra of various samples: PDMC (a) and CPAM (b)

very rough with a large mushroom-shaped structure than PAM. CPAM and PDMC possessed bigger specific surface area, which has a strong adsorption and bridging capabilities with bacteria.^[21] Therefore, it has a good adsorption effect on negatively charged bacteria and fungi.

Antibacterial Properties

Antibacterial Properties was assessed by the growth of colony forming units CFU, after studying the effect of concentration on antibacterial activity, dealing time was studied. The effects of molecular weight and cationicity

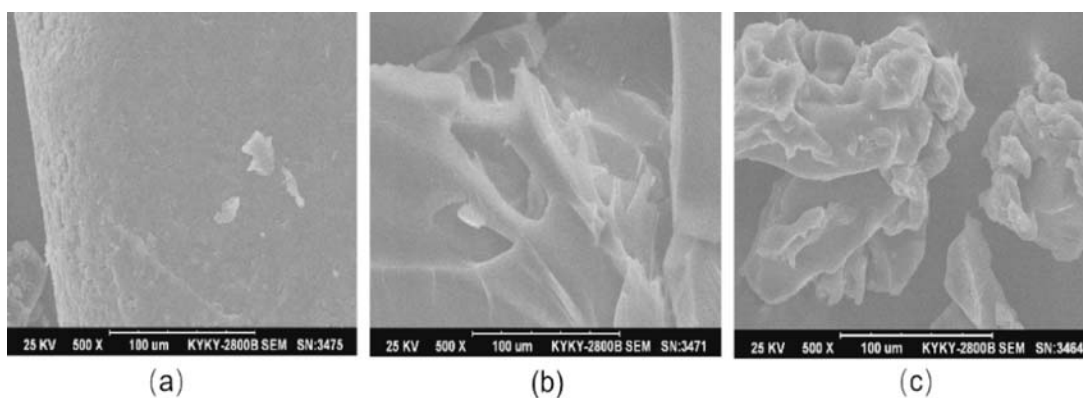

Fig. 6. SEM images of various samples: (a) PAM, (b) CPAM, (c) PDMC

of PQAS on bactericidal activity were also investigated. Antibacterial activity for three kinds of bacteria, *Staphylococcus aureus* (S. A.), *Escherichia coli* (E. coli), *Shigella* and one kind of fungus: *Monilia albican* (M. A.) were also performed.

PDMC and CPAM with similar molecular weight were selected for bacteriostatic assays, as can be seen from Table 3, with the concentration of the bacteriostatic agent increases, the inhibition rate against E. coli and S.A. increases. This is an increase in PQAS in the solution, which increases the damage to the bacterial structure and thus increases the inhibition rate.

Basing QB/T 2738-2012, when the inhibition rate is less than 50%, the sample at this

concentration has no bacteriostatic ability. To this end, CPAM and PDMC were chosen to be made to 10 mg/L, observing the effect of dealing time on inhibition. It can be seen from Table 4 that as the treatment time increases, the inhibition rate of PDMC is basically unchanged, and the inhibition rate of CPAM increases rapidly, and then increases slowly. This may be because there is a large amount of $-N^+-(CH_3)_3$ structure on the PDMC, and the molecular chain is rapidly scatter in water, which can adsorb the bacterial surface very well. However, $-N^+-(CH_3)_3$ on CPAM is less, and CPAM has a larger molecular weight and slowly scatter in water, so the time required to adsorb and destroy bacteria is long. Combining with the values of Tables 2 and 3, basing QB / T 2738-2012, when

TABLE 3. Bacteriostatic performance of PQAS at different concentration, with bacterial concentration $1 \sim 9 \times 10^4$ CFU/mL

Dealing time: 2 min			
Bacteriostatic agent	C mg/L	E. Coli inhibition rate (%)	S. A. inhibition rate (%)
CPAM3	10	30.1	22.57
	20	56.08	50.
	50	70.12	67.32
	100	97.7	86.15
PDMC4	10	99.98	99.02
	20	100	99.78
	50	100	100
	100	100	100

TABLE 4. Bacteriostatic performance of PQAS at dealing time, with bacterial concentration $1 \sim 9 \times 10^4$ CFU/mL

Concentration: 10 mg/L			
Bacteriostatic agent	Dealing time /min	E. Coli inhibition rate (%)	S. A. inhibition rate (%)
CPAM3	2	30.1	22.57
	5	91.6	89.9
	10	98.79	95.02
PDMC4	2	99.98	99.02
	5	100	100
	10	100	100

the inhibition rate $\geq 50\%$, the sample of this concentration has bacteriostatic. Therefore, we choose to make the bacteriostatic agent 20 mg/L and dealing time was 2 min for the next study.

From Table 5, the bacteriostatic of CPAM2 and CPAM5, CPAM4 and PDMC3 were compared, which have similar molecular weight but different cationicity, and it was found that the inhibition rate of E. coli and S.A. increased with increasing cationicity in the polymer. When the molecular weight of PQAS is similar, the degree of cationic in PQAS increases, which means

that the structure of $-N^+(\text{CH}_3)_3$ in the aqueous solution increases, the mutual repulsion between molecular chains increases, and molecular chain of PQAS can be dispersed in water quickly. At this time, PQAS will adsorb better on the bacterial surface. Therefore, at the same molecular weight, increasing the cationicity of the polymer, and the inhibition rate also increases.

When PQAS has the same cationicity, we compared the bacteriostatic ability of CPAM2 and CPAM5, PDMC1, PDMC3 and PDMC5 with

TABLE 5. Antibacterial performance of PQAS, with bacterial concentration $1 \sim 9 \times 10^4$ CFU/mL.

Bacteriostatic agent	C mg/L	E. Coli inhibition rate (%)	S. A. inhibition rate (%)
CPAM2	20	1.5	0
CPAM4	20	99	98.04
CPAM5	20	100	99.5
PDMC1	20	99.5	99.3
PDMC3	20	100	99.5
PDMC5	20	100	100

different molecular weight. It can be seen from Table 5 that as the molecular weight of PQAS increases, the antibacterial ability of PQAS against E. coli and S. A. is also enhanced. As the molecular weight of PQAS increases, the much $-N^+-(CH_3)_3$ structures are carried on the polymer molecular chain. The PQAS molecular chain can stretch in solution due to the repulsion between the $-N^+-(CH_3)_3$ structures, thereby exposing much $-N^+-(CH_3)_3$ structures to bacteria, and neutralized by bacteria, increasing the antibacterial ability of PQAS.

Further, to explore whether the PQAS has a broad antibacterial spectrum, there are two microbial strain: Shigella, M. A. were selected for antimicrobial test in vitro. The bacteriostatic agents including CPAM4, PDMC1, PDMC2, PDMC3 with a concentration and dealing time

fixed at 40 mg/L and 2 min, respectively. As shown in Table 6, combining with the results of S. A. and E. coli treated with the same bacteriostatic agent in Table 5, it can be found that antimicrobial activity of PQAS for different bacteria strain has an order: Escherichia coli (E. coli) > Staphylococcus aureus (S. A.) > Shigella > Monilia albican (M. A.). PQAS has weak antibacterial ability to M.A. and good inhibition ability to E. coli, S. A. and Shigella. This is because E. coli, S. A. and Shigella are three kinds of bacteria, but M. A. is a fungus with a unique cell wall structure. Therefore, the ability of the $-N^+-(CH_3)_3$ structure in PQAS to adsorb to the cell membrane of M. A. is weakened, and the destruction of the M.A. structure is more difficult, resulting in a decrease in its antibacterial ability.

TABLE 6. Antibacterial performance for bacteria and fungus with bacterial concentration $1 \sim 9 \times 10^4$ CFU/mL and bacteriostatic agent concentration fixed at 20 mg/L, within 2 min

Bacteriostatic agent	Antibacterial rate %	
	Shigella inhibition rate (%)	M. A. inhibition rate (%)
CPAM4	95.01	60.36
PDMC1	96.07	73.35
PDMC3	97.06	80.87
PDMC5	98.83	87.36

CONCLUSIONS

In this paper, two kinds of poly quaternary ammonium salts of PDMC and CPAM were prepared by aqueous solution polymerization, and characterized by FT-IR, ¹H NMR, TG and SEM. PDMC and CPAM were successfully prepared and have good thermal stability at ordinary temperature. We tested the antibacterial properties of three kinds of bacteria and one kind of fungus using water-soluble PQAS. The results show that the antibacterial properties of PQAS increase with the increase of the cationicity and the molecular weight of the polymer. Due to the difference in structure between fungi and bacteria, PQAS is significantly more resistant to bacteria than fungi. In addition to, the antibacterial activity of PQAS for different bacteria strain shows different results that, *Escherichia coli* (E. coli) > *Staphylococcus aureus* (S. A.) > *Shigella* > *Monilia albican* (M. A.).

ACKNOWLEDGEMENTS

The authors gratefully appreciate the financial support from the Nation Key R&D Program (2017YFB0308900) and Project of JALA Research Funds (JALA 2017).

REFERENCES

1. A. M. Bonilla, and M. F. García, *Prog. Polym. Sci.* 37 (2012) 281.
2. N. Fierer, M. Hamady, and C. L. Lauber, *P. Natl. Acad. Sci. USA.* 105 (2008) 17994.
3. A. Shafei, M. ElShemy, and A. A. Okeil, *Carbohydr. Polym.* 118 (2015) 83.
4. M. H. Rafie, H. B. Ahmed, and M. K. Zahran, *Carbohydr. Polym.* 107 (2014) 174.
5. V. P. Harden, J. O. Harris, and J. *Bacteriol.* 65 (1953) 198.
6. A. Kanazawa, T. Ikeda, and T. Endo, *J. Polym. Sci. Polym. Chem.* 31(1993) 335.
7. E. R. Kenawy, S. D. Worley, and R. Broughton, *Biomacromolecules.* 8 (2007) 1359.
8. X. Qin, Y. Li, and F. Zhou, *Appl. Surf. Sci.* 328 (2015) 183.
9. T. Ikeda, S. Tazuke, and Y. Suzuki, *Makromol. Chemie.* 185 (1984) 869.
10. A. Zhang, Q. Liu, and Y. Lei, *React. Funct. Polym.* 88 (2015) 39.
11. T. Ikeda, H. Hirayama, and H. Yamaguchi, *Antimicrob. Agents. Ch.* 30 (1986) 132.
12. B. Dizman, L. J. Mathias, *J. Polym. Sci. Polym. Chem.* 43 (2005) 5844.
13. G. Q. Lu, H. J. Zhang, and W. M. Dong, *Chem. Res. Chinese. U.* 28 (2012) 1095.
14. X. Jia, and Y.J. Zhang. *J. Appl. Polym. Sci.* 125 (2012) 1.
15. C. Q. Zhang, Y. J. Jiang, and H. B. Ju, *J. Mol. Liq.* 241 (2017) 638.
16. E. R. Kenawy, F. I. Abdel, and A. E. R. Shanshoury, *J. Polym. Sci. Polym. Chem.* 40 (2002) 2384.
17. E. F. Panarin, M. V. Solovskii, and N. A. Zaikina, *Makromol. Chemie.* 9 (1985) 25.
18. Z. L. Yang, B. Y. Gao, and C. X. Li, *Chem. Eng. J.* 161 (2010) 27.
19. J. Zhu, H. Zheng, and Z. Jiang, *Desalin. Water. Treat.* 51 (2013) 2791.
20. J. Ma, K. Fu, and X. Fu, *Sep. Purif. Technol.* 182 (2017) 134.
21. P. Zhang, D. Zhao, X. Zhang., *Mater. Sci.* 3 (2018) 1.

Received: 20-12-2019

Accepted: 28-01-2020