

## Feature-Based Vibration Monitoring of a Hydraulic Brake System Using Machine Learning

T. M. Alamelu Manghai<sup>1</sup> and R. Jegadeeshwaran<sup>2</sup>

**Abstract:** Hydraulic brakes in automobiles are an important control component used not only for the safety of the passenger but also for others moving on the road. Therefore, monitoring the condition of the brake components is inevitable. The brake elements can be monitored by studying the vibration characteristics obtained from the brake system using a proper signal processing technique through machine learning approaches. The vibration signals were captured using an accelerometer sensor under a various fault condition. The acquired vibration signals were processed for extracting meaningful information as features. The condition of the brake system can be predicted using a feature based machine learning approach through the extracted features. This study focuses on a mechatronics system for data acquisitions and a signal processing technique for extracting features such as statistical, histogram and wavelets. Comparative results have been carried out using an experimental study for finding the effectiveness of the suggested signal processing techniques for monitoring the condition of the brake system.

**Keywords:** Vibration signals, statistical features, histogram features, wavelet decomposition, machine learning, decision tree.

### 1 Introduction

Early detection of the faults can preclude the system from malfunction. Therefore, a decision support tool is necessitated for monitoring the condition of any system to categorize catastrophes. The brake system in an automobile is one such essential control component responsible for the safety. Faults are not fairly noticeable in an automobile brake system. Many studies have been reported in the literature for monitoring the brakes by measuring the parameters like brake temperature, friction force, and braking force [Richard, Marshall, Bailey et al. (2004); Reinecke (1988); Reinecke (1992)]. No such mechatronics system has been proposed for measuring the brake failures such as pad wear, the air in the brake fluid, oil leak, etc. Hence a feature based condition monitoring study has been reported in the present study to monitor the brake system. Vibration and acoustic emission (AE) are the two elements are widely suggested for many fault prediction studies. Ruoyu and David introduced an approach for health monitoring of rotational machine and

---

<sup>1</sup> School of Mechanical and Building Sciences, VIT University Chennai Campus, Chennai, Tamil Nadu, India-600 127.

<sup>2</sup> School of Mechanical and Building Sciences, VIT University Chennai Campus, Chennai, Tamil Nadu, India-600 127.

Email: krjegadeeshwaran@gmail.com.

detecting fault location using Empirical Mode Decomposition (EMD)-based AE measurement [Li and He (2012)]. Elasha et al investigated the internal AE and external vibration measurement to identify the bearing fault in a helicopter gearbox. The bearing fault signatures were extracted using a signal processing technique [Elasha, Greaves, Mba et al. (2015)]. The AE signal is stochastic in nature. AE techniques require sophisticated sensors and data acquisition hardware. Hence, the vibration signal analysis is one of the comprehensive and convenient elements for the analysis.

Bozhidar et al discussed vibration estimation with piezoelectric transducers and their application. The elements of change are tentatively characterized and examined [Dzhudzhev, Ivancheva, Kachulkova et al. (2013)]. Saruhan et al. described that the vibration examination system is a solid and precisely detecting system which detects to defect in the rolling element bearings (REBs) [Saruhan, Sarodemir, Çiçek et al. (2014)]. Ragini et al. reviewed recent research and advancements in rolling bearing vibration analysis techniques. The bearing fault and bearing characteristic frequencies (BCF) were discussed and reviewed [Sidar, Prakash and Gopal (2015)]. Haifeng et al. proposed a novel fault detection technique for solenoid-operated valves (SOV) based on vibration signal measurement. The amplitude of the vibration signal was separated by a de-noising algorithm based on its analyzed signals, to detect faults and Wavelet [Guo, Wang and Xu (2016)]. These measured vibration signals should be analyzed to get the meaningful conclusion. In vibration analysis, the vibration can be analyzed using either using Time domain analysis or a frequency domain analysis. The frequency domain analysis using Fast Fourier Transform (FFT) was traditionally followed approach for frequency domain analysis. However, FFT is not suitable for non-stationary signals.

Katalin Agoston presented a method for detecting electrical and mechanical faults which occur frequently in an induction motor. Each type of faults (electrical or Mechanical faults) creates a vibration with a particular frequency. Through monitoring and analyzing the vibration spectrum these particular fault conditions can be detected [Agoston (2015)]. Zhou et al introduced a winding vibration model combined with electromagnetic force examination for measuring the twisting vibrations under different conditions [Zhou (2016)]. Buono et al. investigated to detect possible cavitation issue by implementing a proper numerical system. Bianchini et al. [Bianchini, Immovilli, Cocconcelli et al. (2011)] presented a diagnostic strategy based on the vibration analysis to distinguish faults. They have also investigated the physical connection between faults and vibration spectrum parts and the improvement of a kinematic model to anticipate fault frequencies for limited faults on linear roller bearings. Nasiri et al. [Nasiri, Mahjoob, Vahid-Alizadeh et al. (2011)] presented the mechanized cavitation fault detection in centrifugal pumps using vibration signature investigation. A neural network model was developed to distinguish the defective conditions. Bossio et al [Bossio, Bossio and De Angelo (2013)] proposed a new strategy for processing vibration signals in order to detect and analyze faults in variable speed wind turbines with permanent magnet synchronous generators. The proposed strategy depends on a resampling of the procured vibration signals with a specific speed independent vibration spectrum. The hydraulic brake system is also producing the vibration under different operating conditions. The produced vibration directly relates to the fault conditions. Hence, vibration is the most suited one for a condition monitoring study [Buonoa (2017)].

The vibration signatures captured from the brake system is non-stationary because of wear and tear. A proper signal processing techniques can solve such problems [Alamelu Manghai, Jegadeeshwaran and Sugumaran (2017)]. Nowadays, retrieving the meaningful information contained in the vibration signals are the alternate way for analyzing the signals based on its signature. The commonly used indices are the features which can be computed from the raw vibration signal and which highlight differences between records, making them useful for fault diagnosis and trending [Guo, Wang and Xu (2016)]. The vibration signals can be examined using techniques like wavelet analysis, waveform examination, spectral analysis, etc. Such investigation will give the data required to settle on a choice about when intercession is required for maintenance. The consequences of such examination are solved using a machine learning approaches in order to determine the original cause of the fault. In recent years, feature based study on machine learning approach is gaining momentum in the fault diagnosis field. The feature is an individual quantifiable property or characteristic of a phenomenon being monitored. There are many features such as statistical, histogram, wavelets, and AR-MA through which a detailed fault diagnosis study can be made. There are numerous studies have been reported using statistical features [Sugumaran and Ramachandran (2011); Jegadeeshwaran and Sugumaran (2015)]. However, there is a huge scope for other features such as histogram and wavelets. Hence, in this study, vibration signal acquisition and vibration signal analysis for extracting information as features in a brake system has been discussed with the help of an experimental study.

The paper is structured as follows:

The experimental setup, experimental procedure, and fault simulation procedure have been described in Section II. Vibration signal analysis has been discussed in Section III. Statistical feature extraction and histogram feature extraction has been discussed in Section IV and V. Wavelet feature extraction has been discussed in Section VI. The effectiveness of the feature extraction techniques have been evaluated and a comparative study has been discussed in Section VII.

## **2 Experimental Studies**

The effectiveness of the features on the classification accuracy is the main objective of this study. An experimental study was carried out for finding the right features for monitoring the brake system.

### ***2.1 Experimental setup***

A commercial passenger vehicles (Maruti Swift) brake system was considered as an experimental test model (Figure 1) [Jegadeeshwaran and Sugumaran (2013)]. The test setup consists of the disc and rear drum brake coupled together by a common drive shaft which was run by a DC motor (1HP). The vibration signals were acquired using data acquisition hardware.



**Figure 1:** Experimental Setup-Hydraulic Brake system

A wireless Data Acquisition (DAQ-Model NI 9234, 4 channel, 51.2 k Samples/sec) hardware was used for acquiring the vibration signals (Figure 2). The data acquisition hardware consists an inbuilt signal-conditioning unit, charge amplifier and an analog-to-digital converter (ADC). The vibration signal in digital form was captured using NI-Lab VIEW. Vibration signal was acquired using the piezoelectric type shear accelerometer. An uni-axial accelerometer (500 g range, 10 mV/g sensitivity and) as shown in Figure 3 was used for acquiring the vibration signals. Figure 4 shows the chassis used for vibration signal acquisition. Vibration signal was acquired using the piezoelectric type shear accelerometer. An uni-axial accelerometer (500 g range, 10 mV/g sensitivity and) as shown in Figure 3 was used for acquiring the vibration signals. Figure 4 shows the chassis used for vibration signal acquisition.

## **2.2 Experimental Procedure**

Initially, all the components were assumed to be good (i.e. brand new brake components were used). The vibration signals were acquired under the constant parameters (Wheel speed: 667 rpm; brake force: 7 kgf) using the accelerometer. Then, the most frequently occurring faults were simulated one at a time on the brake system and the corresponding vibration signals were acquired. The following faults namely, Air in the brake fluid, Oil spill on the brake disc, drum brake pad wear, disc brake pad wear (Inner, inner and outer, uneven-inner, uneven-inner & outer), mechanical fade, brake oil leak were simulated one at a time while all other components remain in good condition and the corresponding vibration signals were acquired [Jegadeeshwaran and Sugumaran (2013)].

The vibration signals were captured from the brake system with the following settings [Jegadeeshwaran and Sugumaran (2015)]:

- 1) *Sample length:* 1024 chosen arbitrarily.
- 2) *Sampling frequency:* 24 kHz (As per Nyquist sampling theorem).
- 3) *Number of samples:* Minimum of 55 trials.

Once the faults were simulated, the vibration signals were recorded. Figure 5. shows the graphical program which was used for the vibration signal acquisition. Figure 6 and Figure

7 show the sample vibration signals acquired from the brake system under good and air in brake fluid condition respectively.



**Figure 2:** Data acquisition hardware-NI9234-4 channel DAQ

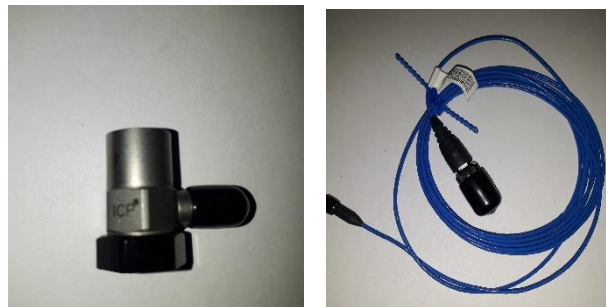

**Figure 3:** IEPE type accelerometer



**Figure 4:** Data acquisition hardware with CDAQ chassis NI9191

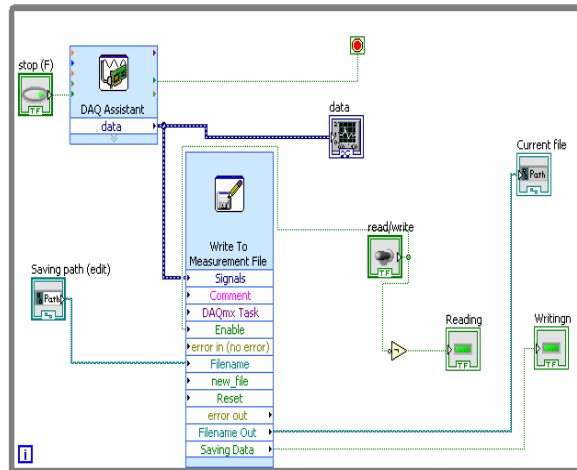

**Figure 5:** LabVIEW graphical program for acquiring the signals.

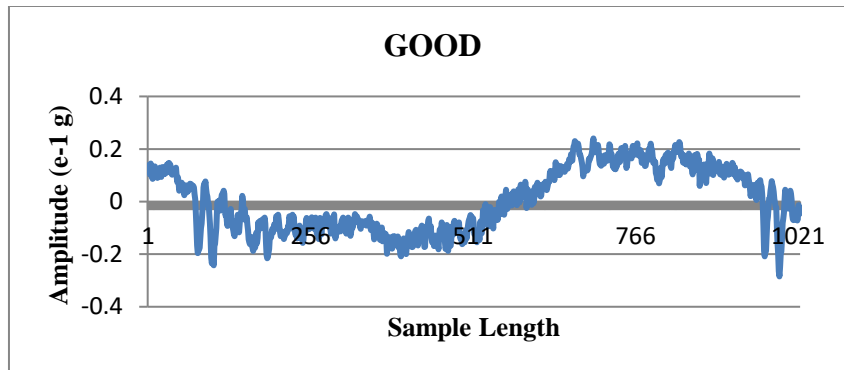

**Figure 6:** Sample vibration signal under good condition.

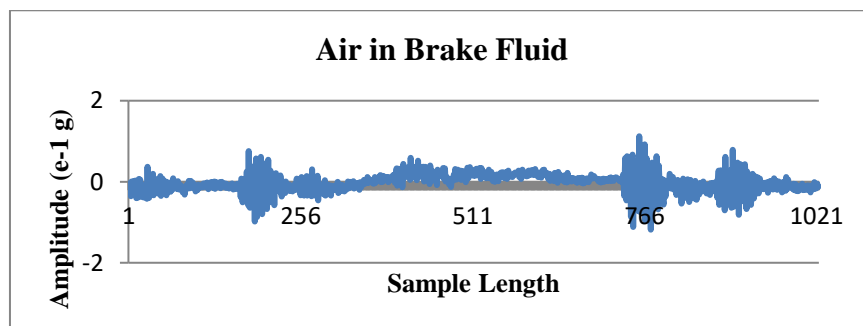

**Figure 7:** Sample vibration signal under air in brake fluid condition.

### 3 Vibration signal analysis

Vibration analysis is an indispensable part of many conditions monitoring programs for

rotating equipment, and each analyst comprehends the significance of using frequency-based spectra to recognize machine faults. The vibration-based diagnosis has been the most prominent monitoring strategy due to the simplicity of measurement. At the point when vibration elements of a segment are obtained, its health condition can be dictated by comparing these patterns with those relating to its typical and failure conditions. One such technique which is commonly employed for the condition monitoring approach is feature extraction technique. Many features can be extracted from to vibration signals. They are (i) Statistical feature, (ii) histogram feature, and (iii) wavelet feature.

**3.1 Statistical feature extraction**

The statistical features can be extracted from the time domain signals frequency domain signals. Many authors have studied the statistical feature extraction techniques for various CM applications. Chinmaya et al. [Chinmaya, Kar and Mohanty (2008)] proposed a statistical feature extraction technique to find a detection of defects in a multistage gearbox under transient loads. Saravanan et al. [Saravanan, Cholairajan and Ramachandran (2009)] described the extraction of statistical features from the vibration signals acquired under different fault conditions of the gearbox. Shen et al. [Shen, Wang, Kong et al. (2013)] proposed a new intelligent machine fault diagnosis scheme based on the extraction of statistical parameters from the wavelet packet transform (WPT) clearing, a distance evaluation technique (DET) for the dimensionality reduction of the feature space for making health status decision mechanism.

**Table 1: Statistical Features**

Name of the Statistical Features	Formula/Description
Standard error	$\sqrt{\frac{1}{n-2} \left[ \sum (y - \bar{y})^2 - \frac{\sum [(x - \bar{x})(y - \bar{y})]^2}{\sum (x - \bar{x})^2} \right]}$
Standard Deviation	$\sqrt{\frac{n \sum x^2 - (\sum x)^2}{n(n-1)}}$
Sample Variance	$\sqrt{\frac{n \sum x^2 - (\sum x)^2}{n(n-1)}}$
Kurtosis	$\left\{ \frac{n(n+1)}{(n-1)(n-2)(n-3)} \sum \left( \frac{x_i - \bar{x}}{S_d} \right)^4 \right\} - \frac{3(n-1)^2}{(n-2)(n-3)}$
Skewness	$\frac{n}{(n-1)(n-2)} \sum \left( \frac{x_i - \bar{x}}{S_d} \right)^3$

Li et al. [Li, Zhu, Jiang et al. (2015)] described a feature extraction and evaluation technique for the rotating machinery fault diagnosis. Based on the central limit theory, an

extraction method was given to get the statistical features with the assistance of a signal processing apparatuses. The statistical features can be extracted using visual basic macro code [Jegadeeshwaran and Sugumaran (2015)] and Matlab.

The statistical examination of the vibration signals yields diverse statistical parameters. Like, mean, median, mode, standard error, standard deviation, minimum, maximum, sum, count, crest factor, impulse factor, K-factor, shape factor, sample variance, skewness, kurtosis [Sujatha (2010)]. These statistical features can be extracted from the vibration signals using either Matlab code or a visual basic program. Table 1 shows the formulae used for extracting the statistical features from the raw vibration signals.

### 3.2 Histogram feature extraction

A distinction in the scope of amplitude for various classes could be seen when the size of the signs was measured in a time domain. Variation in the vibration amplitude can be visualized as a histogram plot. This histogram gives some significant data to characterize the fault condition [Elangovan (2011); Kankar, Satish and Harsha (2011)].

Indira et al. illustrated the systematic mathematical approach based on histogram features extracted from the vibration signal, to pick the number of bins and the minimum number of samples required to train the classifier with factual strength in order to get best grouping precision [Indira, Vasanthakumari, Sakthivel et al. (2011)]. Madhusudana et al. presented the blame finding of the face milling tool in view of machine learning approach using histogram features and K-star algorithm strategy. Histogram features were extracted from the gained vibration signals acquired from acquired signal [Madhusudana, Hemantha and Narendranath (2016)].

Joshuva and Sugumaran presented a vibration based wind turbine blade fault detection approach through histogram feature analysis [Joshuva and Sugumaran (2016)]. Figure 8 shows the sample histogram feature extracted from two bin ranges.

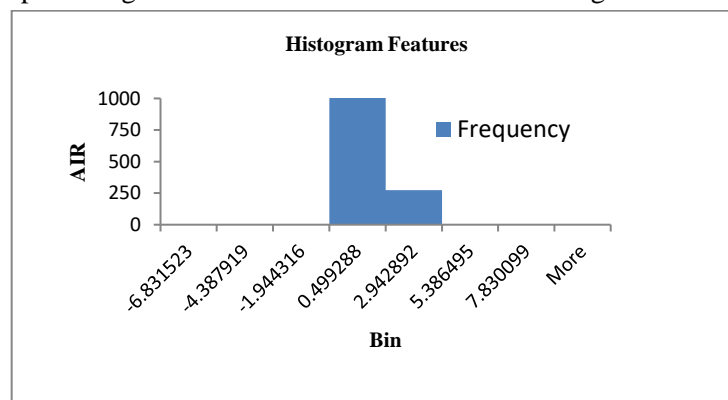

**Figure 8:** Sample histogram features extracted from the vibration signals

### 3.3 Wavelet feature extraction

The wavelet transform (WT) is a time-frequency deterioration of a signal into an arrangement of wavelet basis functions. The Continuous Wavelet Transform (CWT) and the Discrete Wavelet Transform (DWT) are the two different features which are frequently



used in various fault diagnosis approaches.

The wavelet transform of  $f(t)$  is defined as

$$WT_f(a, b) = \langle f(t), \Psi_{a,b}(t) \rangle = \frac{1}{\sqrt{a}} \int_0^{\infty} f(t) \Psi\left(\frac{t-b}{a}\right) dt, \quad (1)$$

Where  $\Psi_{a,b}(t)$  is the scaled and shifted version of the transforming function, called a “mother wavelet” or “base wavelet”, which is defined as

$$\Psi_{a,b}(t) = \frac{1}{\sqrt{a}} \Psi\left(\frac{t-b}{a}\right), \quad (2)$$

Where  $t, a, b \in \mathbb{R}$ ,  $a \neq 0$  is continuous variables,  $a$  is scale factor of the base wavelet the is responsible for “resolution” analysis, and  $b$  is a shift factor that is responsible for location on the time axis. The function  $\Psi_{a,b}(t)$  is called the base wavelet (or mother wavelet) and is continuous wavelet when parameters  $t, a, b$  changes continuously. The discrete wavelet analysis can be implemented by the scaling filter, which is a low pass filter related to the scaling filter, which is low pass filter related to the scaling function  $\phi(t)$  and the wavelet filter, which is a high-pass filter related to the wavelet function  $\Psi(t)$ .

Discrete wavelets do the scaling and translation operations in discrete steps, limiting the choice of wavelet scales and translation  $a$  and  $\tau$  to discrete numbers, but the analysis is still sufficiently accurate. This is expressed in the below form,

$$\Psi_{j,k}(t) = \frac{1}{\sqrt{s_0^j}} \Psi\left(\frac{t - k\tau_0 s_0^j}{s_0^j}\right) \quad (3)$$

where  $j$  and  $k$  are integers.

There are many studies have been reported in the literature for various studies. The time scale space is sampled at discrete intervals as a result of discretizing the wavelets. It results in series of wavelet coefficients, and the process is called wavelet series decomposition [Roshan, Chandan and Ajoy (2014)]. Baydar et al. [Baydar and Ball (2003)] examined the acoustic signals with WT to recognize the different faults in gearboxes. Peng and Chu presented the application of the wavelet transform in machine fault diagnostics. These vibration signals were separated into few principle angles, including the time-frequency examination of signals, the singularity recognition for signals, the de-noising and extraction of the powerless signals, the fault feature extraction, the pressure of vibration signals and the system identification [Peng and chu (2004)]. Saravanan and Ramachandran presented the layout of discrete wavelet transforms and afterward exhibited a model to investigate the vibration signals created by a bevel gearbox under different fault conditions [Saravanan and Ramachandran (2010)]. Newland [Newland (1994)] described the applications of the wavelet transform for extracting features from the vibration signals and for fault detection and diagnosis. Jing et al. [Jing and Qu (2000)] proposed a de-noising method based on the wavelet analysis extraction of mechanical vibration signals and they have successfully applied it for detecting faults in the roller bearing. Seker et al. [Seker and Ayaz (2003)] described a systematic approach for extracting the features from the vibration signals measured from the 5-HP motors to identify the impacts of bearing faults under each aging cycle of induction motors. Muralidharan et al. [Muralidharan and Sugumaran (2012)] presented the discrete wavelet features extracted from the vibration signals of good and defective conditions mono-block centrifugal pumps.

Using wavelets to expel noise from a signal requires distinguishing which segment or segments contain the noise, and afterward recreating the signal without those parts. In this case, less noisy and more high-frequency data was filtered out of the signal. During this stage, the loss of a significant number of the original signal's sharpest features is inevitable. Hence, a suitable approach called thresholding is required for optimal denoising. This includes discarding of just the bit of the subtle elements that exceeds a certain limit.

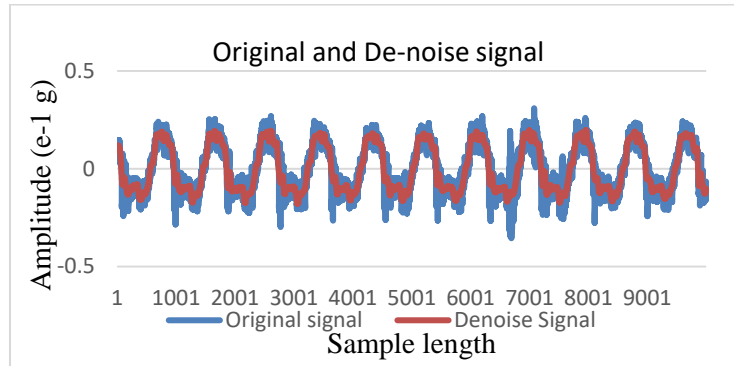

**Figure 9:** Original and de-noised signal under good condition

The thresholding value is changed level to level. The Wavelet features can be extracted for every condition using the Daubechies wavelets "db 1" to "db15". Based on the literature study, the level 5 approximation was used for the de-composition [Saravanan and Ramachandran (2010)]. From each db wavelets, the relevant statistical features were extracted. The wavelet features can be extracted from the vibration signals using MATLAB graphical user interface. Figure 9 shows the original and de-noised signal of a vibration signal acquired under good condition. Figure 10 shows the decomposition of the db wavelet under each level (from db 1 to db 5).

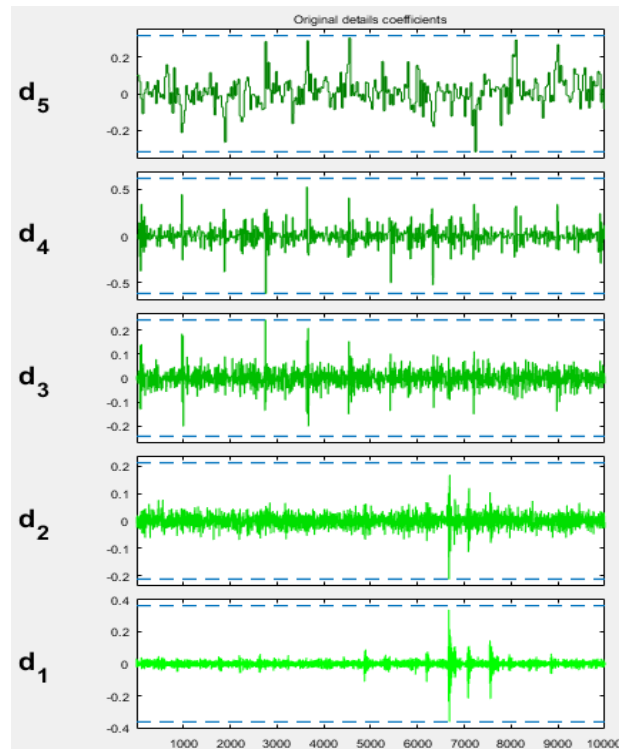

**Figure 10:** Decomposition signal for Daubechies wavelets (level 5)

## 4 Results and Discussion

The experiment was carried out for finding the better features extraction techniques for monitoring the health condition of a signal. All the features extracted through feature extraction techniques were classified using a decision tree algorithm to find the effectiveness of the features extracted from the vibration signals. A decision tree is a tree-based knowledge structure used to select features through the classification rules [Peng, Flach, Brazdil et al. (2002)]. Decision trees are built using a top-down approach. A J48 decision tree is an algorithm used to generate a decision tree which can be used for both feature selection and feature classification. Jegadeeshwaran and Sugumaran used decision tree algorithm for segregating the fault conditions of a hydraulic brake system [Jegadeeshwaran and Sugumaran (2014)].

### 4.1 Statistical feature classification using decision tree

- 1) Twelve statistical features namely, maximum, minimum, mean, skewness, standard error, median, standard deviation, kurtosis, range, sum, variance, and count were extracted from the acquired raw vibration signal through visual basic code.

**Table 2:** Statistical Features extracted from the raw vibration signals

Statistical Features	Value
Mean	-0.00253707
Standard Error	0.00238446
Median	0.004668
Mode	-0.066255
Standard Deviation	0.238446019
Sample Variance	0.056856504
Kurtosis	1.901427642
Skewness	-0.089974498
Range	2.476281
Minimum	-1.213803
Maximum	1.262478
Sum	-25.37070428
Count	10000

- 2) All the extracted features were classified using the decision tree algorithm.
- 3) The input to the algorithm was the extracted features; the output was a classification accuracy.
- 4) The decision tree provides 97.09% classification accuracy over the statistical features that were extracted from the raw vibration signals.

Total number of data points	550
Total number of data points that are correctly classified	534
Total number of data points that are misclassified	16
Classification accuracy	97.09%

- 5) The decision tree uses a 10-fold cross validation for finding the classification accuracy.
- 6) Table 2 shows the sample statistical features extracted from the raw vibration signals.

#### **4.2 Histogram feature classification using decision tree**

- 1) The value between the maximum and minimum value of the vibration signal was divided into a number of frequency ranges called as bins.
- 2) Totally 70 bins were extracted from the vibration signal. All the 69 bin ranges (2-70) were classified one by one using a decision tree algorithm.
- 3) Table 3 shows the sample histogram features extracted from the vibration signals under 59<sup>th</sup> bin.
- 4) The bin range 59 produced better classification accuracy as 97.83%.

Total number of data points	550
Total number of data points that are correctly classified	538

Total number of data points that are misclassified 12  
 Classification accuracy 97.83%

- 5) Here also, the 10-fold cross-validation was used for the classification purpose.
- 6) Compared to statistical features, the histogram features produced a better accuracy.

**Table 3:** Histogram features extracted from the raw vibration signal

H26	H27	H28	H29	H30	H31	H32
0	0	1863	5724	2413	0	0
0	2	1956	5630	2412	0	0
0	2	1930	5622	2446	0	0
0	0	1899	5435	2666	0	0
0	2	1960	5687	2351	0	0
0	0	2017	5539	2444	0	0

**4.3 Wavelet feature classification using decision tree algorithm**

- 1) The original signal was decomposed using the Daubechies wavelets.
- 2) From the final decomposed de-noised signal, the relevant features were extracted. Figure 9 and Figure 11 show the original and de-noised signal using Daubechies wavelets (level 5) for good and air in brake fluid condition respectively.

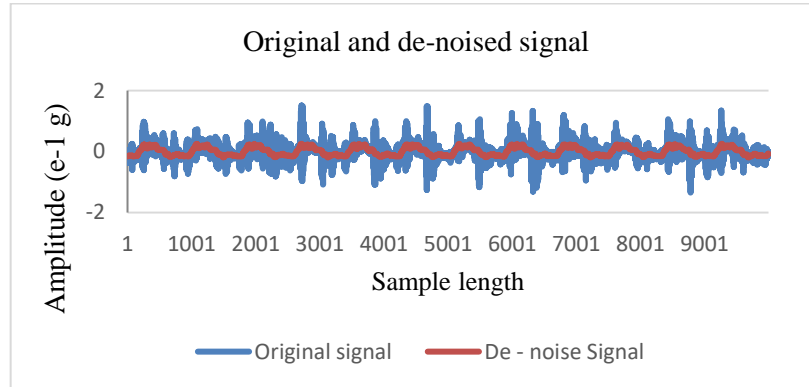

**Figure 11:** Decomposed vibration signals using Daubechies wavelets

- 3) Table 4 shows the threshold values used for de-composing the signals.
- 4) Table 5 shows the sample statistical features extracted from the decomposed signals.
- 5) The extracted features were classified using the decision tree algorithm.
- 6) The wavelet features produced 96.06% classification accuracy using 10-fold cross-validation.

Total number of data points 550  
 Total number of data points that are correctly classified 528

Total number of data points that are misclassified	22
Classification accuracy	96.06%

**Table 4:** Thresholded value for decomposition signal

Level	Threshold value
1	1.976
2	1.109
3	0.218
4	0.753
5	0.391

**Table 5:** Statistical Features extracted from the decomposed wavelet signals

Statistical Features	Value
Mean	- 0.002748489
Standard Error	0.001346671
Median	-0.052772291
Mode	0
Standard Deviation	0.134667065
Sample Variance	0.0181352
Kurtosis	-1.38358
Skewness	0.365127
Range	0.446107
Minimum	-0.191509
Maximum	0.2545979
Sum	-27.484894
Count	10000

#### **4.4 Comparative study**

- 1) It is often needed to compare all the three feature extraction technique for identifying the better feature set for the fault diagnosis study.
- 2) Table 5 shows the histogram and statistical features produced better accuracy over the wavelets for the same vibration signals.
- 3) In particular, the histogram features produced a better accuracy than the other two features.
- 4) Hence, the histogram can be taken as a better feature for the fault diagnosis study.
- 5) The objective of this research is to find the effective feature extraction for a brake fault diagnosis study.
- 6) The vibration signals acquired from the brake system can be analyzed using a statistical

learning process as discussed above. There is no much study on the histogram and wavelet features for a hydraulic brake system. Hence, this research outcome will help the researchers who are doing research in the brake health condition monitoring study.

**Table 5:** Overall Classification Accuracy-Comparative study

<i>S. No</i>	<i>Name of the Classifier</i>	<i>Classification Accuracy (%)</i>
1	Statistical features	97.09
2	Histogram features	97.83
3	Wavelet Features	96.06

## 5 Conclusion

In this paper, the possible feature extraction techniques were discussed for a brake fault prediction process through machine learning. It deals with the vibration analysis based on the features extracted from the raw vibration signals. The vibration signals were acquired using a piezo-electric transducer through a data acquisition process. Set of statistical, histogram and wavelet features were extracted from the vibration signal using feature extraction techniques. The effectiveness of the feature extraction techniques was studied using a model based classification procedure through machine learning. The decision tree algorithm was used for finding the effectiveness of the features that were considered in the study. From the decision tree results, the histogram features produced a better result than the other two features. Hence, this histogram and decision tree combination can be considered for the practical applications of the fault diagnosis study on the hydraulic brake system.

## References

- Alamelu Manghai, T. M.; Jegadeeshwaran, R.; Sugumaran, V.** (2017): Brake fault diagnosis through machine learning approaches-a review. *Structural Durability & Health Monitoring*, vol. 12, no. 1, pp. 43-67.
- Baydar, N.; Ball, A.** (2003): Detection of gear failures via vibration and acoustic signals using wavelet transform. *Mechanical Systems and Signal Processing*, vol. 17, no 4, pp. 787-804.
- Bossio, J. M.; Bossio, G. R.; De Angelo, C. H.** (2013): Fault detection for variable-speed wind turbines using vibrations and electrical measurements. *IEEE Brazilian Power Electronics Conference*, pp. 487-492.
- Dzhudzhev, B.; Ivancheva, V.; Kachulkova, S.; Gospodinova, E.** (2013): Vibration Measurement with Piezoelectric Transducer. *ICEST*, pp. 705-708.
- Shen, C. Q.; Wang, D.; Kong, F. R.; Peter, W. T.** (2013): Fault diagnosis of rotating machinery based on the statistical parameters of wavelet packet paving and a generic support vector regressive classifier. *Measurement*, vol. 46, pp. 1551-1564.
- Kar, C.; Mohanty, A. R.** (2008): Vibration and current transient monitoring for gearbox fault detection using multi resolution Fourier transform. *Journal of Sound and Vibration*, vol. 311, no. (1-2), pp. 109-132.

**Bianchini, C.; Immovilli, F.; Cocconcelli, M.; Rubini, R.; Bellini, A.** (2011): Fault detection of linear bearing in Brushless AC Linear Motors by Vibration Analysis. *IEEE Transaction on industrial Electronics*, vol. 58, no. 5, pp. 1648-1694.

**Buonoa, D.; Siano, D.; Frosina, E.; Senatore, A.** (2017): Gearmotor pump cavitation monitoring and fault diagnosis using vibration analysis through the employment of autoregressive-moving-average technique. *Simulation Modelling Practice and Theory*, vol. 71, pp. 61-82.

**Elangovan, M.; Babu Devasenapati, S.; Sakthivel, N. R.; Ramachandran, K. I.** (2011): Evaluation of an expert system for condition monitoring of a single point cutting tool using principle component analysis and decision tree algorithm. *Expert Systems with Applications*, vol. 38, pp. 4450-4459.

**Reinecke, E.** (1988): Apparatus for the measurement and/or of a braking torque. *U.S pat No.* 4790606.

**Elasha, F.; Greaves, M.; Mba, D.; Addali, A.** (2015): Application of Acoustic Emission in Diagnostic of Bearing Faults within a Helicopter gearbox. *Procedia CIRP*, vol. 38, pp. 30-36.

**Guo, H. F.; Wang, K.; Xu, A. D.** (2016): A Novel Method of Fault Detection for Solenoid Valves Based on Vibration Signal Measurement. *IEEE International Conference on Internet of Things and IEEE Green Computing and Communications*, pp. 870-874.

**Zhou, H.; Hong, K.; Huang, H.; Zhou, J.** (2016): Transformer winding fault detection by vibration analysis methods. *Applied Acoustics*, vol. 114, pp. 136-146.

**Indira, V.; Vasanthakumari, R.; Sakthivel, N. R.; Sugumaran, V.** (2011): A method for calculation of optimum data size and bin size of histogram features in fault diagnosis of mono-block centrifugal pump. *Expert Systems with Applications*, vol. 38, pp. 7708-7717.

**Jegadeeshwaran, R.; Sugumaran, V.** (2013): Comparative study of decision tree classifier and best first tree classifier for fault diagnosis of automobile hydraulic brake system using statistical features. *Measurement*, vol. 46, pp. 3247-3260.

**Jegadeeshwaran, R.; Sugumaran, V.** (2014): Vibration based fault diagnosis of a hydraulic brake system using Variational Mode Decomposition (VMD). *Structural Durability and Health Monitoring*, vol. 10, no. 1 pp. 87-91.

**Jegadeeshwaran, R.; Sugumaran, V.** (2015): Brake fault diagnosis using Clonal Selection Classification Algorithm(CSCA) eA statistical learning approach. *Engineering Science and Technology, an International Journal*, vol. 18, pp. 14-23.

**Jegadeeshwaran, R.; Sugumaran, V.** (2015): Health Monitoring of a Hydraulic Brake System Using Nested Dichotomy Classifier–A Machine Learning approach. *International Journal of Prognostics and Health Management*, vol. 6, no. 1, pp. 1-14.

**Lin, J.; Qu, L. S.** (2000): feature extraction based on morlet wavelet and its application for mechanical fault diagnosis. *Journal of Sound and Vibration*, vol. 234, no. 1, pp. 135-148.

**Joshuva, A.; Sugumaran, V.** (2017): A data-driven approach for condition monitoring of wind turbine blade using vibration signals through best-first tree algorithm and functional trees algorithm: A comparative study. *ISA Transactions*, vol. 67, pp. 160-172.



- Kankar, P. K.; Satish, C. S.; Harsha, S. P.** (2011): Fault diagnosis of ball bearings using machine learning methods. *Expert Systems with Applications*, vol. 38, pp. 1876-1886.
- Agoston, K.** (2015): Fault detection of the electrical motors based on vibration analysis. *Procedia technology*, vol. 19, pp. 547-553.
- Madhusudana, C. K.; Hemantha, K.; Narendranath, S.** (2016): Condition monitoring of face milling tool using K-star algorithm and histogram features of vibration signal. *International Journal Engineering Science and Technology*, vol. 19, no. 3, pp. 1543-1551.
- Muralidharana, V.; Sugumaran, V.** (2012): A comparative study of Naïve Bayes classifier and Bayes net classifier for fault diagnosis of monoblock centrifugal pump using wavelet analysis. *Applied Soft Computing*, vol. 12, pp. 2023-2029.
- Nasiri, M. R.; Mahjoob, M. J.; Vahid-Alizadeh, H.** (2011): Vibration signature analysis for detecting cavitation in centrifugal pumps using neural network. *Proceedings of the 2011 IEEE International Conference on Mechatronics*, pp. 632-635.
- Newland, D. E.** (1994): Wavelet analysis of vibration Part I: Theory. *Journal of Vibration and Acoustics*, vol. 116, pp. 409-416.
- Nowicki, R.; Slowinski, R.; Stefanowski, J.** (1992): Evaluation of vibro-acoustic diagnostic symptoms by means of the Rough Sets Theory. *Computers in Industry*, vol. 20, pp. 141-152.
- Peng, Y. H.; Flach, P. A.; Brazdil, P.; Soares, C.** (2002): Decision tree-based data characterization for meta-learning, *ECML/PKDD-2002 Workshop IDDM-2002*, Helsinki, Finland.
- Peng, Z. K.; Chu, F. L.** (2004): Application of the wavelet transform in machine condition monitoring and fault diagnostics: a review with bibliography. *Mechanical Systems and Signal Processing*, vol. 18, pp. 199-221.
- Sidar, R.; Prakash, K. S.; Gopal, S.** (2015): Review of vibration-based fault diagnosis in rolling element bearing and vibration analysis techniques. *International Journal of Scientific Research Engineering & Technology*, vol. 4, no. 10, pp. 998-1003.
- Miller, R.; Marshall, R.; Bailey, D. A.; Griffin, N. C.** (2004): Brake condition monitoring, *U.S. Pat No. US 0011596A1*.
- Martis, R. J.; Chakraborty, C.; Ray, A. K.** (2014): Wavelet-based machine learning techniques for ECG signal analysis, machine learning in healthcare informatics. *Intelligent Systems Reference Library*, vol. 56, pp. 25-45.
- Li, R. Y.; He, D.** (2012): Rotational machine health monitoring and fault detection using EMD-based acoustic emission feature quantification. *IEEE Transactions on Instrumentation and Measurement*, vol. 61, no. 4, pp. 990-1001.
- Saravanan, N.; Cholairajan, S.; Ramachandran, K. I.** (2009): Vibration-based fault diagnosis of spur bevel gear box using fuzzy technique. *Expert Systems with Applications*, vol. 36, pp. 3119-3135.
- Saravanan, N.; Ramachandran, K. I.** (2010): Incipient gear box fault diagnosis using discrete wavelet transform (DWT) for feature extraction and classification using the artificial neural network (ANN). *Expert Systems with Applications*, vol. 37, pp. 4168-4181.

**Saruhan, H.; Sarodemir, S.; Çiçek, A.; Uygur, O.** (2014): Vibration analysis of rolling element bearings defects. *Vibration Analysis of Rolling Element Bearings Defects*, vol. 12, pp. 384-395.

**Seker, S.; Ayaz, E.** (2003): Feature extraction related to bearing damage in electric motors by wavelet analysis. *Journal of the Franklin Institute*, vol. 340, pp. 125-134.

**Sugumaran, V.; Ramachandran, K. I.** (2011): Fault diagnosis of roller bearing using fuzzy classifier and histogram features with focus on automatic rule learning. *Expert Systems with Applications*, vol. 38, pp. 4901-4907.

**Sujatha, C.** (2010): Vibration and acoustics: measurement and signal analysis. *Tata McGraw Hill Education Private Limited*, 2010.

**Li, W.; Zhu, Z. C.; Jiang, F.; Zhou, G. B.; Chen, G. A.** (2015): Fault diagnosis of rotating machinery with a novel statistical feature extraction and evaluation method. *Mechanical Systems an Signal Processing*, vol. 50-51, pp. 414-426.

## Appendix A

VB Code for extracting statistical features:

For i = 1 To 55

  ChDir \_

    "F:\Academics\BFD-Latest\_signals\Air in brake fluid"

  Workbooks.OpenText Filename:= \_

    "F:\Academics\BFD-Latest\_signals\Air in brake fluid\a (" & i & ").lvm" \_

    , Origin:=437, StartRow:=1, DataType:=xlDelimited, TextQualifier:= \_

    xlDoubleQuote, ConsecutiveDelimiter:=False, Tab:=True, Semicolon:=False, \_

    Comma:=False, Space:=False, Other:=False, FieldInfo:=Array(Array(1, 1), \_

    Array(2, 1)), TrailingMinusNumbers:=True

  Application.Run "ATPVBAEN.XLAM!Descr", ActiveSheet.Range("\$B:\$B"), "", "C"

  —

    , False, True

  Range("B3:B15").Select

  Selection.Copy

  Windows("Book1").Activate

  Range("A" & i & "").Select

  Selection.PasteSpecial Paste:=xlPasteValues, Operation:=xlNone, SkipBlanks \_

    :=False, Transpose:=True

  Windows("a (" & i & ").lvm").Activate

  ActiveWindow.Close

  Next i

End Sub

**Appendix B**

VB Code for extracting histogram features:

```
Sub BFD_Hist()  
,  
' BFD_Hist Macro  
  
For i = 1 To 55  
    Workbooks.OpenText Filename:= _  
        "F:\Academics\BFD-Latest_signals\Air in brake fluid\a (" & i & ").lvm" _  
        , Origin:=437, StartRow:=1, DataType:=xlDelimited, TextQualifier:= _  
        xlDoubleQuote, ConsecutiveDelimiter:=False, Tab:=True, Semicolon:=False, _  
        Comma:=False, Space:=False, Other:=False, FieldInfo:=Array(Array(1, 1), _  
        Array(2, 1)), TrailingMinusNumbers:=True  
    Windows("Book1").Activate  
    Windows("a (1).lvm").Activate  
    Range("P1").Select  
    ActiveSheet.Paste  
    Application.Run "ATPVBAEN.XLAM!Histogram", ActiveSheet.Range("$B:$B"), ""  
    _  
    , ActiveSheet.Range("$P:$P"), False, False, False, False  
    Range("B2:B15").Select  
    Selection.Copy  
    Windows("Book1").Activate  
    Range("A" & i & "").Select  
    Selection.PasteSpecial Paste:=xlPasteValues, Operation:=xlNone, SkipBlanks _  
        :=False, Transpose:=True  
    Windows("a (" & i & ").lvm").Activate  
    ActiveWindow.Close  
Next i  
End Sub
```