

# Leak Detection of Gas Pipelines Based on Characteristics of Acoustic Leakage and Interfering Signals

Lingya Meng<sup>1,\*</sup>, Cuiwei Liu<sup>2</sup>, Liping Fang<sup>2</sup>, Yuxing Li<sup>2</sup> and Juntao Fu<sup>3</sup>

<sup>1</sup>College of Information and Control Engineering, China University of Petroleum, Qingdao, China.

<sup>2</sup>Provincial Key Laboratory of Oil and Gas Storage and Transportation Safety, University of Petroleum, Qingdao, China.

<sup>3</sup>China SINOPEC Natural Gas Corporation, Beijing, China.

\*Corresponding Author: Lingya Meng. Email: chuyun2323@163.com.

**Abstract:** When acoustic method is used in leak detection for natural gas pipelines, the external interferences including operation of compressor and valve, pipeline knocking, etc., should be distinguished with acoustic leakage signals to improve the accuracy and reduce false alarms. In this paper, the technologies of extracting characteristics of acoustic signals were summarized. The acoustic leakage signals and interfering signals were measured by experiments and the characteristics of time-domain, frequency-domain and time-frequency domain were extracted. The main characteristics of time-domain are mean value, root mean square value, kurtosis, skewness and correlation function, etc. The features in frequency domain were obtained by frequency spectrum analysis and power spectrum density, while time-frequency analysis was accomplished by short time Fourier transform. The results show that the external interferences can be removed effectively by the characteristics of time domain, frequency domain and time-frequency domain. It can be drawn that the acoustic leak detection method can be applied to natural gas pipelines and the characteristics can help reduce false alarms and missing alarms.

**Keywords:** Leak detection; acoustic method; signal processing; external interference; characteristic extraction

## 1 Introduction

When the leak or rupture of gas pipeline occurs, the gas outflows from the leakage point and the pressure balance in the gas pipeline is ruined, which generates leakage acoustic waves. The signals propagate through the gas to both of upstream and downstream of the pipeline. The acoustic sensors installed at each monitoring end of pipeline can receive signals and confirm whether a leak has happened. However, field instruments, apparatus and acquisition system can generate random noise and a variety of external interferences can cause noise signals. Moreover, the leakage signals will be flooded by the noise signals. Under this circumstance, the leakages will not be detected accurately, and it will cause false alarms and missing alarms. DOLPHIN intelligent acoustic leak detection system adopted the main sensor and reference sensor to collect the acoustic signals, adaptive filtering was used to distinguish inference signals. However, this system only had high accuracy under low-pressure condition (0~1 MPa), the effectiveness of system under high pressure was still not reported. Acoustic system incorporated (ASI) utilizes pattern recognition technology to exclude external disturbance according to the waveform characteristics, but this process is complex and need to be re-screened under different operation conditions, which needs a huge workload.

Pal-Stefan Murvay [1] presented the state-of-the-art in leak detection and localization methods.

Additionally, they evaluated the capabilities of these techniques to identify the advantages and disadvantages of different leak detection solutions.

Compared with other methods, the acoustic method has many advantages, such as higher sensitivity, more accurate leak location, lower false alarm rate, quicker leak detection and higher adaptability, especially in a longer detection distance. The acoustic method is of great significance, and various studies have been carried out on this method. Lingya Meng [2] established a formula for gas pipelines leak location, which is modified with consideration of the influences of temperature and pressure to calculate time differences. As a result, the location accuracy can be significantly improved with relative errors between 0.01% and 1.37%. Y. Gao [3] developed an analytical model to predict the cross correlation function of leak signals in plastic water pipes, which can be used to calculate the time difference and improve leak location accuracy. M. J. Brennan [4] presented a new interpretation of the process of cross-correlation for time delay estimation. The results demonstrated that the time delay estimations and their variances calculation using time and frequency domain methods are almost identical. It is known that the time difference calculation is important for the method to detect and locate the leakages. However, before that, the characteristics extraction using de-noising methods is necessary. Many research studies have been carried out in the method of characteristics extraction. Lay-Ekuakille [5] developed an alternative method based on the filter diagonalization method (FDM), which is mainly used in nuclear magnetic resonance, to overcome the limitations of the FFT (fast Fourier transform) approach. Yang [6] provided a method and apparatus for detecting and locating leaks in a pipeline. Pattern match filtering was used to reduce the false alarm rate, and to increase sensitivity and improve leak location accuracy. The pattern match filter technique can detect the pressure wave generated by a leak but also be discriminated against background noise and pressure disturbance generated by other non-leak sources. Yingchun Ye [7] introduced a noise reduction method of local projection for leakage acoustic series by analyzing frequency distribution and chaos characteristics. The results demonstrated that the local projection method can yield an obvious improvement in time domain statistical indexes by analyzing frequency domain, power spectrum and autocorrelation function. And it can raise the signal-to-noise ratio, which can largely increase the accuracy when extracting the leakage characteristic index. Xing Zhu [8] collected infrasonic waves generated by full-regime rock failure. The collected infrasonic signals are processed and analyzed by using a wavelet-based de-noising method, short-time Fourier transform time-frequency analysis and accumulative ring-down count (ARDC). Liang Lu [9] researched the separation of the blasting vibration signal with low SNR. Compared with traditional methods that have minimal detail extraction ability, fast ICA was used. It was determined that a signal close to the original signal can be separated from a blasting vibration signal with low SNR. Mingshun Li [10] presented a review of vibration signal processing methods. The developments, features and applications were presented and discussed for amplitude domain analysis, such as Fourier transform, correlation analysis in traditional methods, as well as Wigner-Ville distribution, spectral analysis, wavelet analysis, blind source separation, and Hilbert-Huang transform [11-14].

In order to improve the accuracy of gas pipeline leakage detection, reduce the false alarm rate and eliminate the influence of external disturbance on the acoustic leakage signals, this paper studies and analyzed the characteristics of the acoustic leakage signals and interference signals of the gas pipeline, and obtained the parameters set to identify the characteristics of the leakage acoustic signals [15,16]. In this paper, the noises are regarded as background noises which are caused by field instrument, apparatus and acquisition system and the random noises due to the transportation process and electromagnetic interferences. The external interfering noises include the noises caused by the startup and shutdown of the compressor, valve switches, pipeline knocking and other operation interferences. Background noises can be distinguished and removed by the characteristics of time domain, frequency domain and time-frequency domain, which can improve the accuracy of acoustic method and reduce the false alarms.

## 2 Characteristics of Acoustic Signals

Acoustic characteristics for leak detection can be concluded as: characteristics of time-domain,

frequency-domain and time-frequency domain. In this paper, characteristics of time domain are waveform and amplitude, mean value, mean square value, root mean square value, skewness, kurtosis, correlation function and covariance function, etc. The algorithmic methods of time-domain are not mentioned in details. Frequency analysis and power spectral density analysis are carried out to extract characteristics of frequency-domain. Short Time Fourier Transform (STFT) is used to analyze the characteristics of time-frequency domains [17-22].

## 2.1 Characteristics of Acoustic Signals in Frequency Domain

### (1) Spectrum analysis of acoustic signals

Most of acoustic signals can be decomposed into a linear combination of harmonics with different frequencies, generally using the fast Fourier transform (FFT) to calculate the spectrum of acoustic signals. The Fourier transform  $X(f)$  for non-periodic signals  $x_t(t)$  is given by

$$X(f) = \int_{-\infty}^{+\infty} x(t) e^{-j2\pi ft} dt = F[x(t)] \quad (1)$$

where  $t$  is the time;  $f$  is the frequency of the acoustic signal.

### (2) Power spectral density analysis of acoustic signals [23,24]

Random process is infinite in the sense of time, thus the total energy of the random signal is infinite, but the average power of the random signal is limited. Therefore, the average power of limited signal  $x(t)$  is given by

$$\bar{P} = \lim_{T \rightarrow +\infty} \frac{1}{T} \int_{-\frac{T}{2}}^{\frac{T}{2}} x^2(t) dt = \frac{1}{2\pi} \int_{-\infty}^{+\infty} \lim_{T \rightarrow +\infty} \frac{|F_T(j\omega)|}{T} d\omega \quad (2)$$

where  $T$  is the total time;  $\omega$  is the angular frequency.

Considering  $S(\omega) = \lim_{T \rightarrow +\infty} \frac{|F_T(j\omega)|}{T}$ ,  $S(\omega)$  is power spectral density (PSD) of acoustic signals.

## 2.2 Characteristic of Acoustic Signals in Time-Frequency Domain

Joint time-frequency analysis can describe the characteristics in the time and frequency domain and express the relationship between time and frequency. In this paper, Short Time Fourier Transform (STFT) is used. STFT can be divided into time domain window method and frequency domain window method. Provided that non-stationary signal  $x(t)$  is square integral,  $x(t) \in L^2(R)$ ;  $g(\tau)$  are window function and symmetric real function. The basis function  $g_{t,\Omega}(\tau)$  can be given by

$$g_{t,\Omega}(\tau) = g(\tau - t) e^{j\Omega\tau} \quad (3)$$

The core function of FFT  $e^{j\Omega t}$  can be replaced by the basis function  $g_{t,\Omega}(\tau)$ , STFT of acoustic signals  $(x(t))$   $STFT_x(t, \Omega)$  is given by

$$STFT_x(t, \Omega) = \int_{-\infty}^{+\infty} x(\tau) g_{t,\Omega}(\tau) d\tau = \int_{-\infty}^{+\infty} x(\tau) g(\tau - t) e^{-j\Omega\tau} d\tau \quad (4)$$

For the case of signals of discrete time series  $x(n)$ , discrete short time Fourier transform

$STFT_x(n, \Omega)$  is given by

$$STFT_x(n, \Omega) = \sum_m x(m) g_{n, \Omega}(m) = \sum_m x(m) g(n - m) e^{-j\Omega m} \quad (5)$$

where  $n$  is discrete time;  $\Omega$  is angular frequency.

### 3 Experimental Setup

A high-pressure gas pipeline leak detection device is shown in Fig. 1. It consists of a gas-filled stainless steel pipe, approximately 199.35 m in length. The maximum operation pressure of device is 6.4 MPa, the external diameter is 14 mm and the wall thickness is 2 mm. The test section is instrumented with three ball valves and orifices to simulate the leakage points. The distance from the acoustic sensor upstream to those leakage points are 40.34 m, 88.33 m and 149.02 m, respectively. The size of leak point can be controlled by the orifices, ranging from 0.08 mm to 1 mm. Five acoustic sensors (dynamic pressure sensor 106B from PCB corporation) are installed at both end of the pipeline and at three leakage points, the experimental sampling frequency of acoustic signal is 30 kHz. The width of time window is 1500. The devices can simulate leakage condition and a variety of external interference conditions (compressor startup and shutdown, switches of valves and pipeline knocking, etc.). It should be noted that the aim of the work in this paper is to distinguish the leakage signal and interfering signals, thus the original signal gathered by acoustic sensors should be pre-processed by the wavelet transform to remove the background noises.

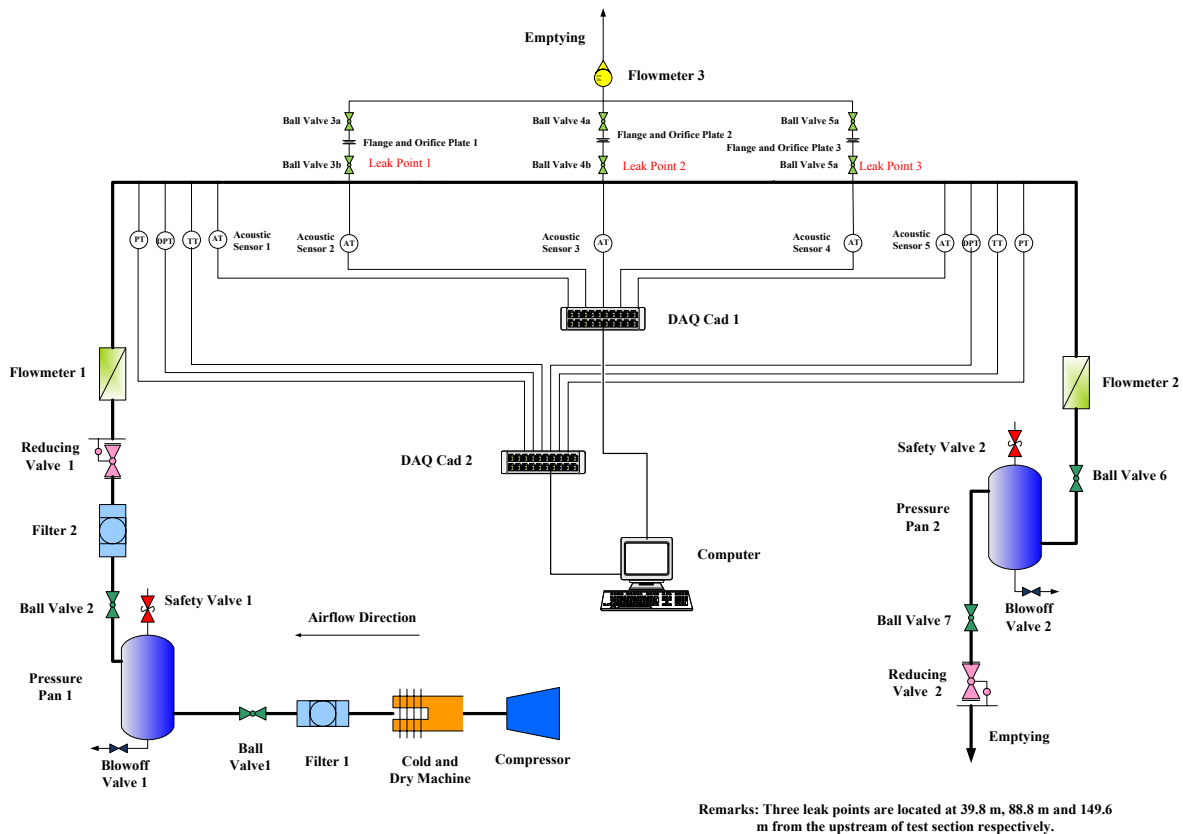

**Figure 1:** Flow chart of leakage experimental device of high pressure gas transmission pipeline

## 4 Results and Discussions

### 4.1 Experimental Analysis of Characteristics in Time Domain

Figs. 2-7 show that the characteristics of acoustic leakage signal and interfering signals (compressor startup and shutdown, switches of valves and pipeline knocking, etc.), respectively standing for the waveform and amplitude, mean value, root mean square value (RMS), skewness and cross-correlation function.

As shown in Fig. 2, when a leak occurs, the acoustic signal has a mutation with a large falling edge, which can be used to estimate whether a leak occurs without any external interference. However, in some conditions, waveform and amplitude of interfering signals (Figs. 2(c), 2(d) and 2(e)) are familiar with those characteristics of leakage signal, which will cause false alarm if waveform and amplitude are relied solely on to leak detection.

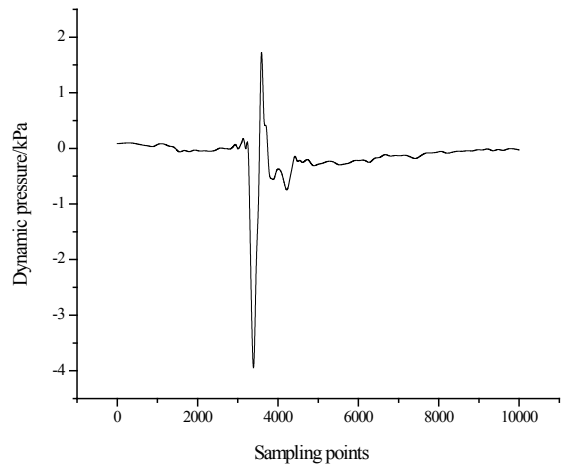

(a) Leakage signal

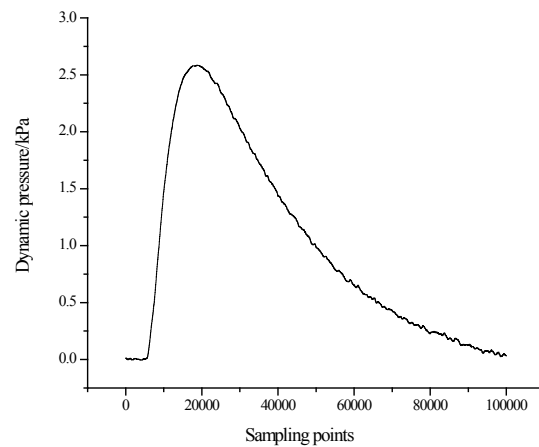

(b) Compressor startup

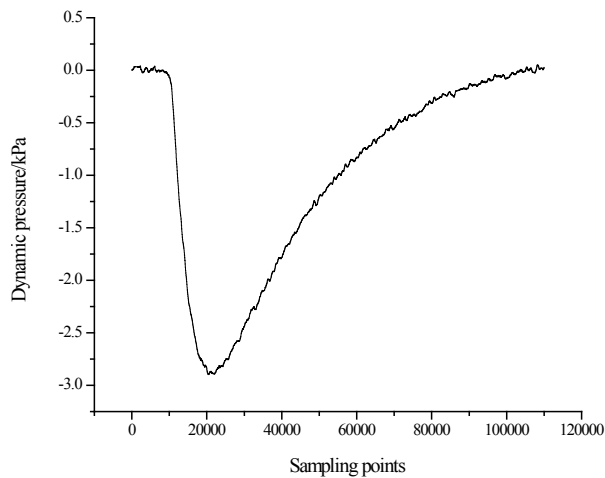

(c) Compressor shutdown

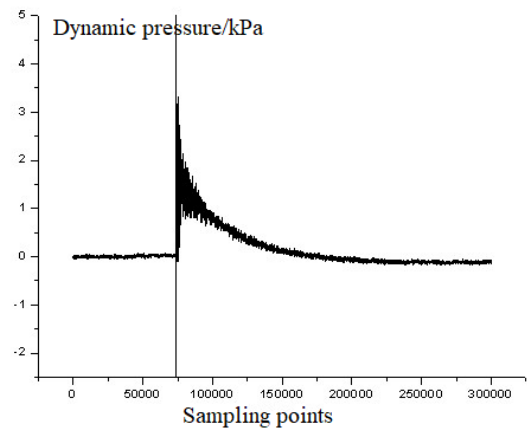

(d) Pipeline knocking

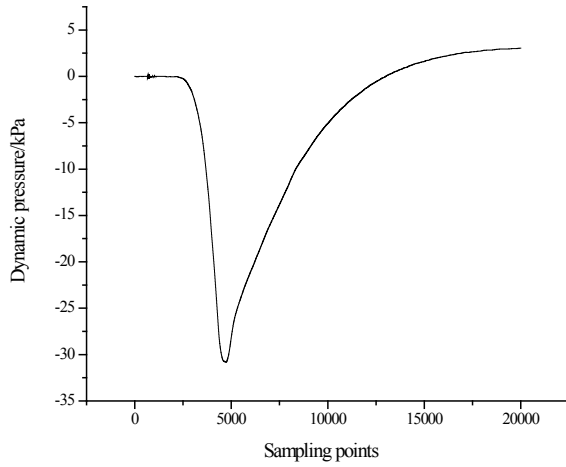

(e) Opening of valve

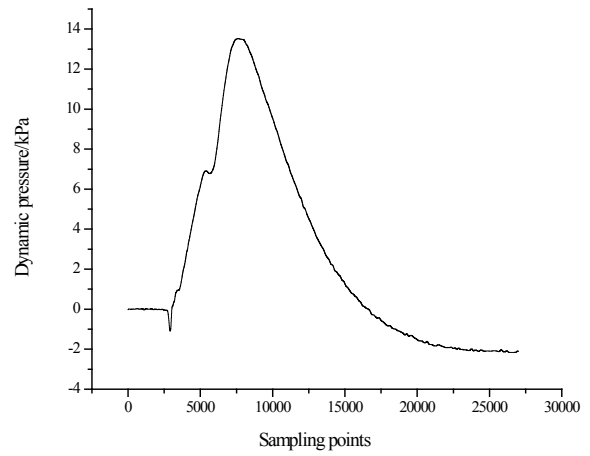

(f) Closing of valve

**Figure 2: Waveform and amplitude of leakage and interfering signals**

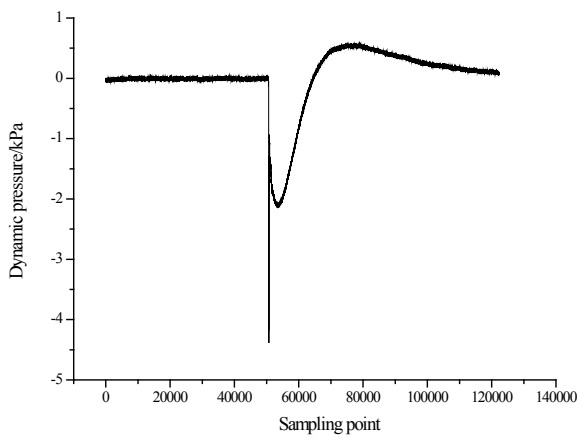

(a) Leakage signal

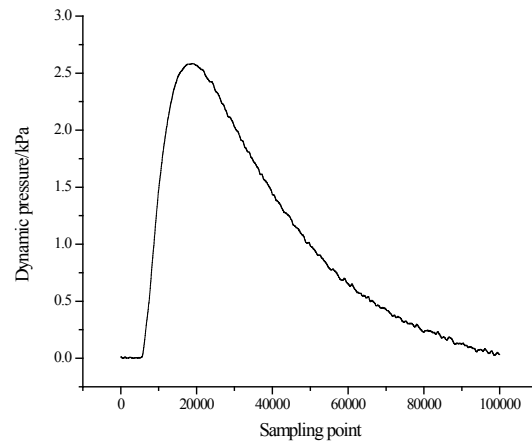

(b) Compressor startup

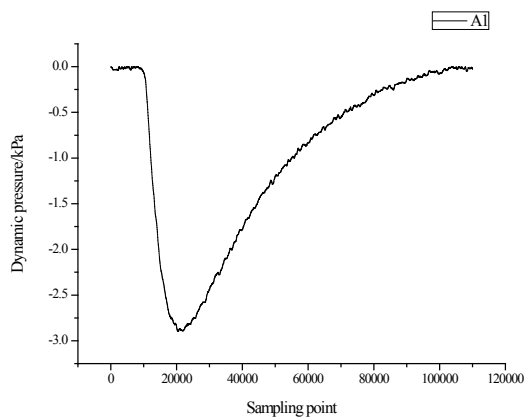

(c) Compressor shutdown

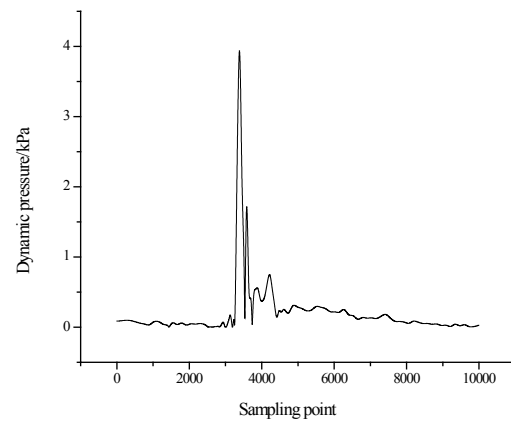

(d) Pipeline knocking

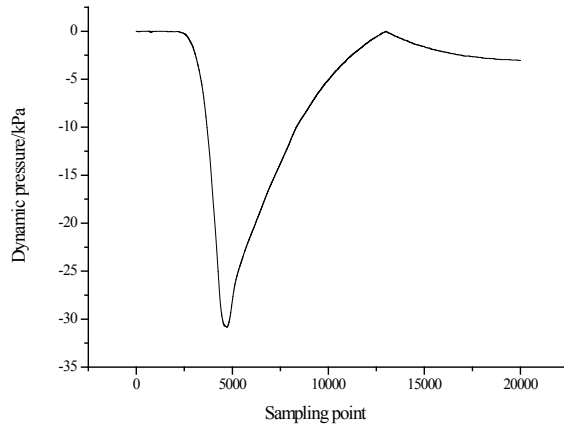

(e) Opening of valve

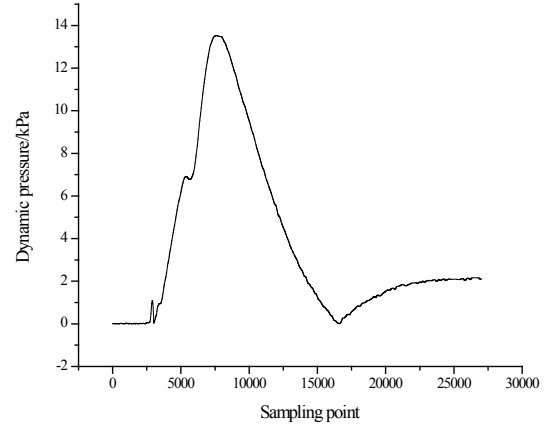

(f) Closing of valve

**Figure 3:** Mean value of leakage and interfering signals

Figs. 2-3 show that there is good agreement between mean value and original signal, retaining the mutation of waveform, but the mean value of knocking signal is different from that of original signal, which can be used as discrimination basis of knocking signal.

Then the standard deviation, root amplitude, mean-square value and RMS are calculated, as seen in Tab. 1.

**Table 1:** The time-domain characteristics

Condition	Condition		
	Leakage	Compressor operation	Operation of valve
Standard deviation	0.4454	0.8545	6.0416
	0.2397	0.7723	4.4231
	0.5738	0.7363	5.2415
	0.4275	0.7853	7.4882
	0.3399	0.8189	6.5114
	0.3232	0.7069	5.5229
	0.4963	0.6131	
	0.6002	0.751	
	0.7123	0.8508	
	0.8707	0.9238	
	0.6596	0.919	
	1.0113	0.9334	
	1.2078	0.9183	
	1.7769	0.8357	
Root amplitude		0.8852	
		0.8346	
	0.21569	0.44867	2.5093
	0.089776	0.51888	2.1417
	0.29131	0.22907	2.406
	0.1328	0.26642	3.3756
	0.12199	0.28347	2.6724
	0.20789	0.2195	2.7299
	0.17561		

	0.075797	0.35723	
	0.10733	0.40021	
	0.11329	0.74467	
	0.11004	0.47557	
	0.10144	0.4869	
	0.1117	0.40128	
	0.13828	0.311	
		0.34324	
		0.30665	
Mean-square value	0.2386	1.1742	39.403
	0.0758	1.1469	21.043
	0.3785	0.6202	29.002
	0.2013	0.8412	57.542
	0.125	0.9615	44.432
	0.1062	0.6313	34.099
	0.2949	0.4391	
	0.3823	0.8367	
	0.5552	1.1378	
	0.8258	1.8784	
	0.45	1.415	
	1.0436	1.4769	
	1.4881	1.2755	
	3.1792	0.8208	
		0.9918	
		0.8636	
RMS	0.4885	1.0836	6.2772
	0.2753	1.0709	4.5872
	0.6152	0.7875	5.3854
	0.4486	0.9172	7.5856
	0.3536	0.9806	6.6657
	0.3258	0.7945	5.8394
	0.543	0.6626	
	0.6183	0.9147	
	0.7451	1.0667	
	0.9087	1.3706	
	0.6708	1.1896	
	1.0216	1.2153	
	1.2199	1.1294	
	1.783	0.906	
		0.9959	
		0.9293	

It can be transformed into figures as shown in Fig. 4.



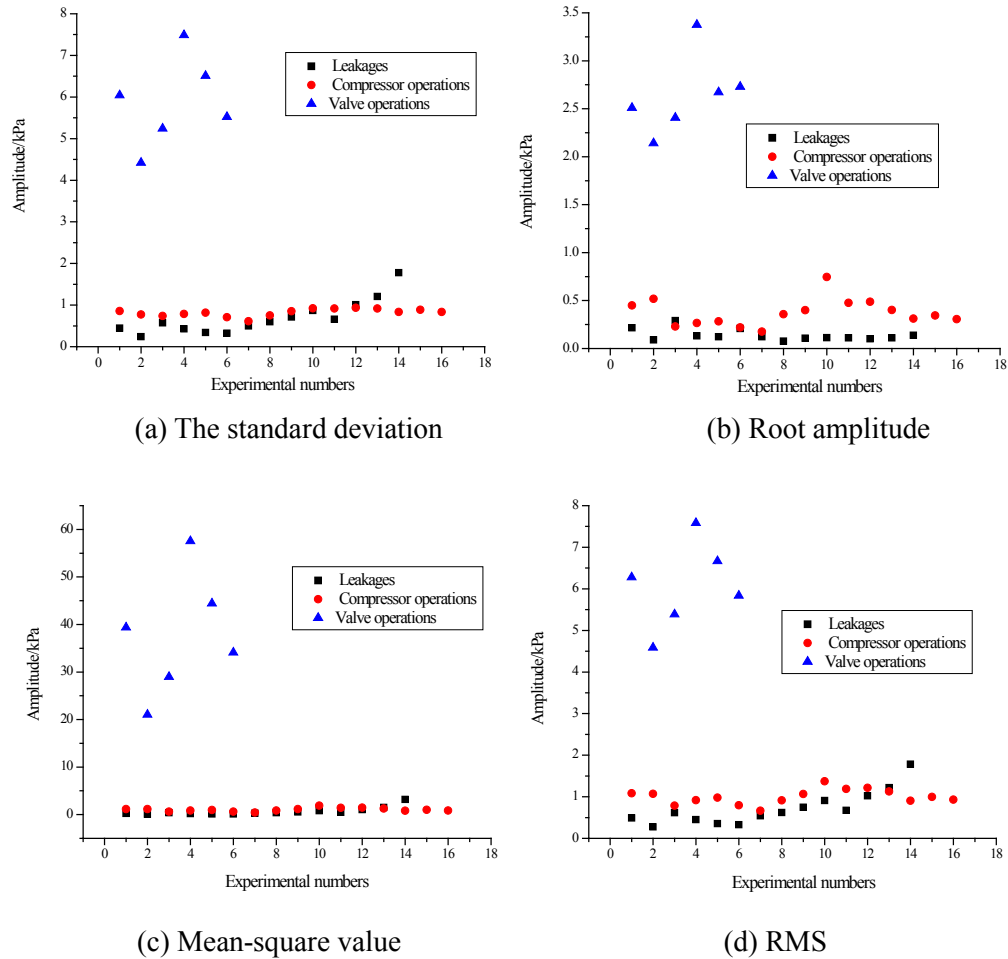

**Figure 4:** Amplitude of the standard deviation, root amplitude, mean-square value and RMS

It can be seen clearly that the signals obtained by the operations of the valve can be distinguished. However, the leakage signals are hard to be distinguished from the signals of compressors.

In addition, several other characteristics are introduced including skewness and kurtosis. The skewness and kurtosis of the overall data of leakage and interfering signals were calculated, as shown in Tab. 2.

It can be known that the leakage signals are totally left-skewed, while knocking signals are always right-skewed. The signals of opening of compressor or valve are all right-skewed, on the contrast, the signals of closing of compressor or valve show all left-skewed, the symbol of which are consistent with the original signals. The kurtosis of overall data of leakage signal is much higher than that of interfering signals, indicating that the probability density function of the leakage signal is steeper than that of interfering signals. Thus, the overall kurtosis of acoustic signal can be a characteristic to distinguish leakage and interfering signals.

**Table 2:** Whole skewness and kurtosis of leakage and interfering signals

Pressure/ MPa	Leak condition		Compressor state	skewness	kurtosis	Valve state	skewness	kurtosis	Pipe knocking	
	skewness	kurtosis							Skewness	kurtosis
1.5	-4.54	33.63	Opening	2.16	6.7	Closing	-0.02	2.98	3.8	18.05
	—	—	Closing	-1.02	2.73	Opening	2.72	9.7	4.1	20.4
2.5	-17.31	383.25	Opening	1.49	3.89	Closing	-3.14	12.48	4.3	22.91
	—	—	Closing	-1	2.62	Opening	2.56	8.71	3.6	16.44
3.5	-19.11	433.67	Opening	1.38	3.54	—	—	—	—	—
	—	—	Closing	-1.2	3.09	—	—	—	—	—
4.5	-17.07	344.23	Opening	1.5	4.11	—	—	—	—	—
	—	—	Closing	-1.74	4.82	—	—	—	—	—
5.5	-19.32	449.66	Opening	2.06	6.1	—	—	—	—	—
	—	—	Closing	-1.51	3.97	—	—	—	—	—

Furthermore, the two added characteristics under different working conditions are presented in Fig. 5.

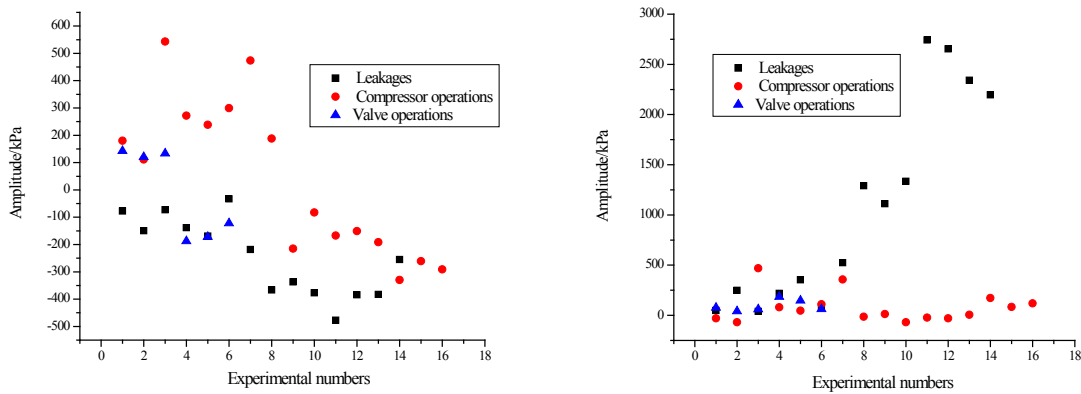

**Figure 5:** Amplitude of whole skewness and kurtosis

**Table 3:** The value ranges of the characteristics including whole skewness and kurtosis

Situations	Leakage	Compressor operations	Valve operations
Skewness	-477.18~-32.749	-329.96~542.89	-187~133.63
Kurtosis	38.551~2741.9	-69.354~469.3	40.513~184.95

The detailed range of the characteristics are showed in Tab. 3. It can be found that the values of different characteristics are overlapping with each other, which indicates that they cannot be used to distinguish the leakage signals from the interference signals.

To solve the problem, the correlation functions (auto-correlation and cross-correlation ) can be tested to see whether they can be used to judge the leakage and interference conditions. The amplitude of auto-correlation function of leakage signals with other interference signals can be seen in Fig. 6.

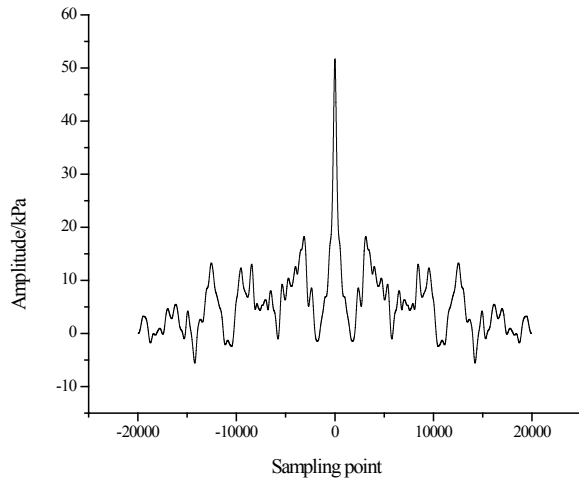

(a) Normal condition

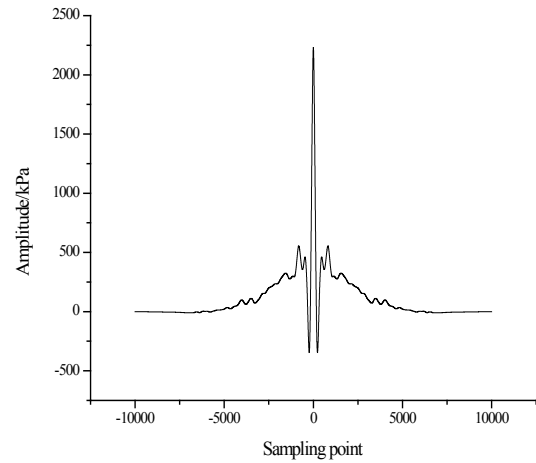

(b) Leakage

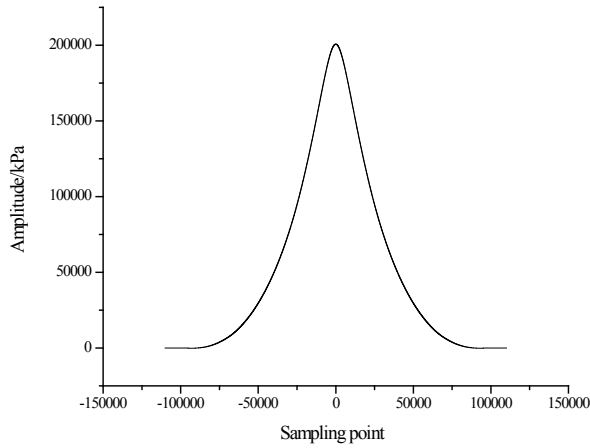

(c) Compressor startup

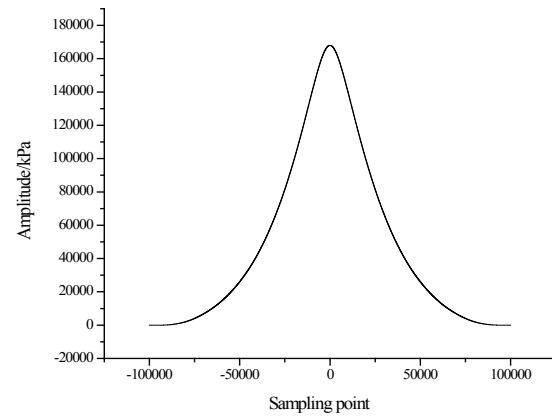

(d) Compressor shutdown

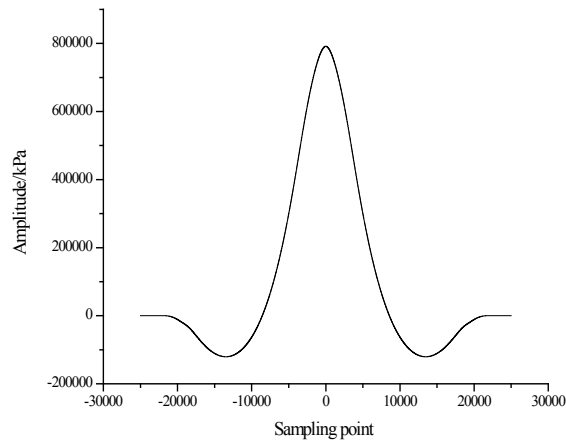

(e) Opening of valve

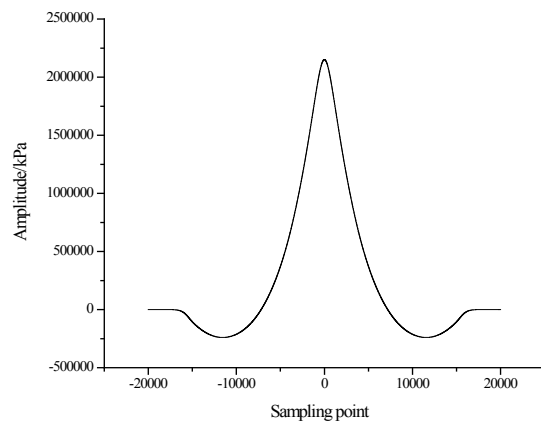

(f) Closing of valve

**Figure 6:** Amplitude of auto-correlation function of different signals

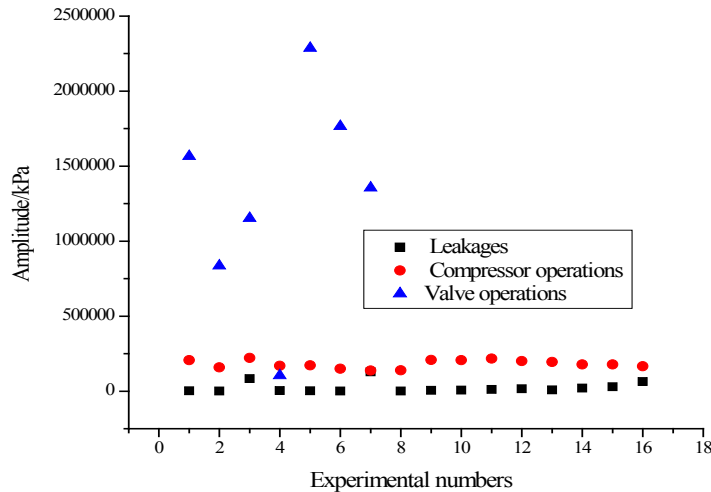

**Figure 7:** Amplitude of auto-correlation function of different signals under different conditions

Under different conditions, the results can be seen in Fig. 7. The amplitudes of auto-correlation function of leakage signals located between 1274 kPa and 10970 kPa while those of compressor operations located between 137700 kPa and 221400 kPa and those of valve operations located between 836400 kPa and 176600 kPa. There is no overlapping between the three signals, which means the auto-correlation function is effective to extract leakage signals. This is consistent with the results of cross-correlation function. In addition, the cross-correlation function of leakage signals can be used to calculate the time differences for leak location.

Overall, Characteristics of leakage and interfering signals in time domain were summarized in Tab. 4.

**Table 4:** Characteristics of time domain of leak signals and interfering signals

Signal types	Leak signal	Compressor signal	Valve signal	Knocking signal
Characteristics	whole kurtosis	Waveform and amplitude, RMS, whole kurtosis	Correlation function, covariance function	Correlation function, covariance function, mean value
Statement	The whole kurtosis is maximum	Waveform is flattest, RMS presents increasing or decreasing trends, the whole kurtosis is minimum	Correlation function and covariance function is maximum	Correlation function and covariance function is minimum, mean value is different from waveform

#### 4.2 Experimental Analysis of Characteristics in Frequency Domain

In this paper, the Fast Fourier Transform was applied to analyze the characteristics of acoustic leakage signals, background noises and interfering signals under the pressure of 5 MPa. Fig. 8(a) shows the amplitude of background noise is small, distributing uniformly in the entire range of frequency, while the energy of leakage signal is mainly concentrated in the low frequency band (0~100 Hz) and the energy in 0~10 Hz is absolutely dominant. And the energy of acoustic signal decreases quickly with the increasing of frequency. Since the energy of leakage signal is much larger than that of background noise in the low frequency band (0~100 Hz), the energy (amplitude) of acoustic signal (0~100 Hz) can be used as a characteristic of leakage condition when there are no external interferences existing.

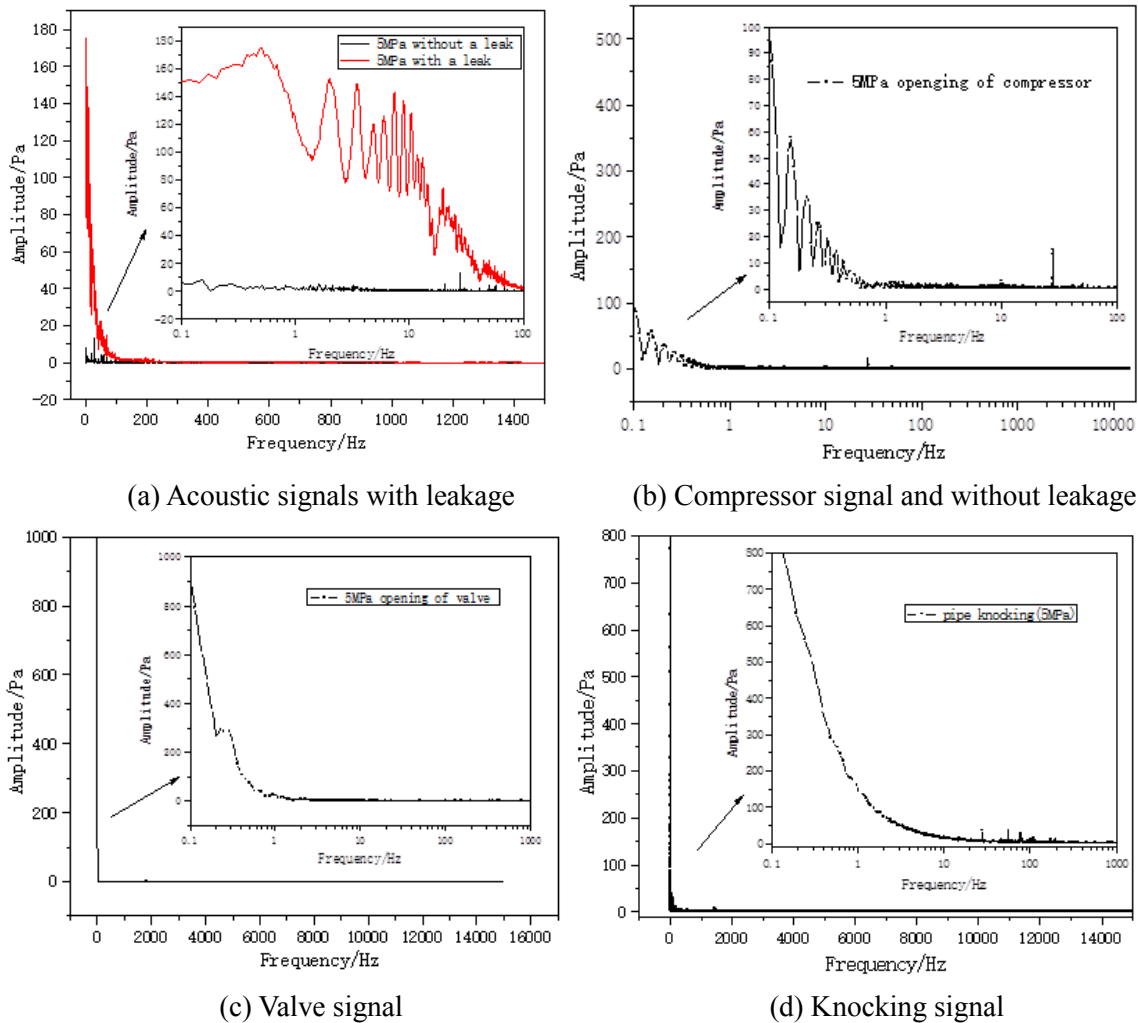

**Figure 8:** Frequency spectrogram of background noise, acoustic leak and interfering signals

Figs. 8(b)-8(d) show the energy of interfering signals are mainly located in the low frequency bands. The amplitude decreases sharply with the increasing of frequency. Compared with the spectrums of leakage signal and interfering signals, the energy of compressor and valve signals focus on the frequency bands of 0~1 Hz, while the energy of knocking signal concentrates in 0~10 Hz. Figs. 8(a)-8(d) show that there are some overlap of energy between leakage and knocking signals, but the whole distributions of energy are different. Therefore, the compressor and valve signal can be ruled out by filtering the acoustic signal in 0~1 Hz with digital filtering. Due to the band overlap of knocking and leakage signals in 1~10 Hz, the knocking signal cannot be excluded only by digital filtering, the combination of characteristics in time-domain and frequency domain should be used to distinguish knocking signal and leakage signal. In addition, when power spectral density was calculated with Welch method, the characteristics in frequency domain is also same with that of spectrum analysis.

#### 4.3 Experimental Analysis of Characteristics in Time-Frequency Domain

Since both the leakage signal and interfering signals are non-stationary, it is necessary to analyze the distribution of characteristics in frequency domain with the change of time to compensate for the shortcomings of Fourier Transform in the analysis of non-stationary signals.

Fig. 9(a) shows the time-frequency distribution of acoustic leakage signal, the red part represents the high energy, while dark blue represents the low energy of acoustic signals. When the pipe is in stable condition (without a leak), the energy in the frequency bands of 0~2.5 kHz is relatively dominant and the maximum value can reach to -60 dB. The energy of acoustic signal without leak remains stable with time, only having a slightly fluctuation. Once a leak occurs (10.9 s), only the energy in low frequency band (0~240 Hz) increases rapidly, and the energy in the frequency band (0~120 Hz) is much higher and can last longer than that in other frequency bands as shown in Fig. 9(b). Noted that the results are consistent with the spectrum analysis in Section 3.2.

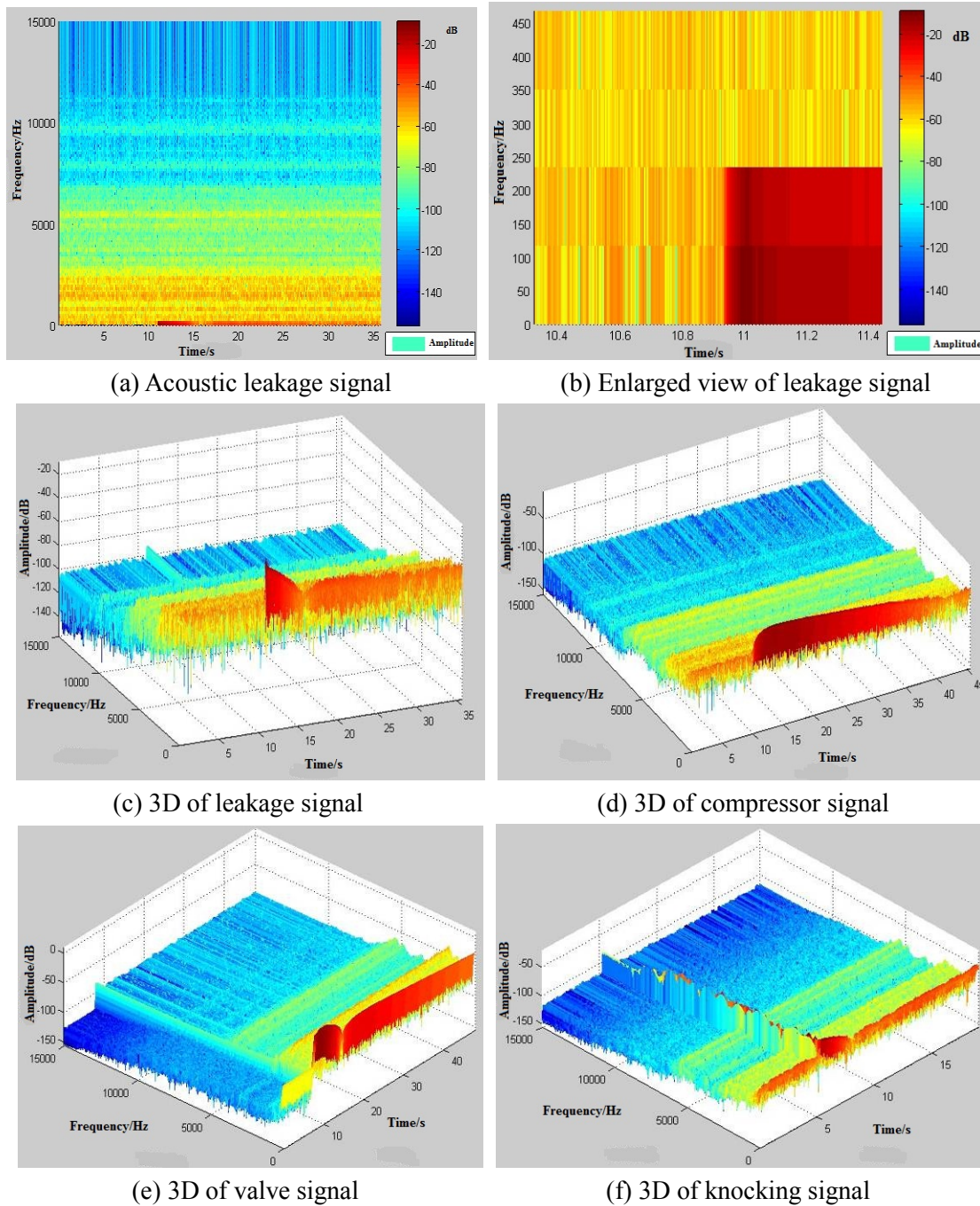

**Figure 9:** Time-frequency analysis of leakage and interfering signals

Fig. 9(c) shows that joint time-frequency analysis of leakage signal. The energy of acoustic leakage signal with a single frequency has a mutation and decreases gradually with time from the view of time-energy domain. And the amplitude of acoustic signal drops quickly with the increasing of frequency. From the point of view of time-frequency-energy domain, there is a mutation in the entire range of frequency, but the mutation in low frequency band is much stronger than that in high frequency band. Meanwhile, the amplitude of acoustic leakage signal attenuates over time and the attenuation in low frequency band is much smaller than that in high frequency bands.

Fig. 9(d) shows that the action of compressor can also cause the increasing of the amplitude of acoustic signals, but the impacts are located in the low frequency bands and the changes of amplitude are relatively slow. Fig. 9(e) shows the amplitude of valve signal rises in the entire range of frequency, but there are bigger mutations in low frequency band. In addition, the amplitude in low frequency has a smaller attenuation than that in high frequency band. Fig. 9(f) shows the amplitude of pipe knocking signal increases uniformly in the whole frequency band. Therefore, the characteristics of acoustic leakage and interfering signal in time-frequency domain can be obtained in Tab. 5.

**Table 5:** Characteristics of time-frequency domain of leak signals and interfering signals

Signal types	Leak signal	Compressor signal	Valve signal	Knocking signal
Characteristics	whole kurtosis	Waveform and amplitude, RMS, whole kurtosis	Correlation function, covariance function	Correlation function, covariance function, mean value
Statement	The whole kurtosis is maximum	Waveform is flattest, RMS presents increasing or decreasing trends, the whole kurtosis is minimum	Correlation function and covariance function is maximum	Correlation function and covariance function is minimum, mean value is different from waveform

**4.4 Characteristics for Leak Detection**

From analysis above, it can be known that characteristics of time-domain, time-frequency domain extracted from acoustic signals can be used to distinguish the leakage signals. In order to verify the results of the characteristics, methods of artificial neural network are applied. The counting process can be seen in Fig. 10.

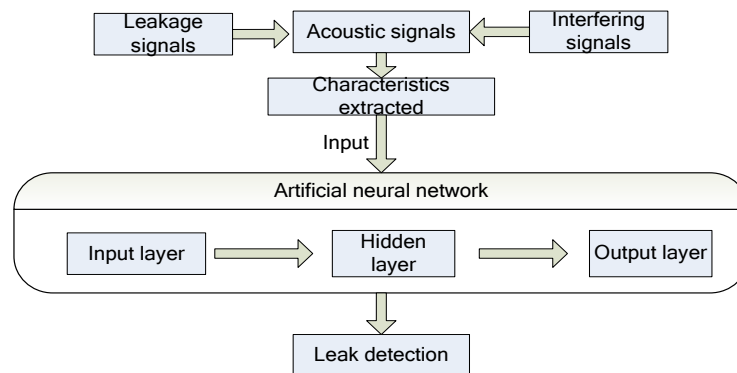

**Figure 10:** The counting process by methods of artificial neural network

In artificial neural network, the Probabilistic Neural Networks (PNN) [22] and Back Propagation (BP) are applied. The Probabilistic neural networks(PNN) is applied and it is one of MATLAB toolbox, it can be used for classification problems. When an input is presented, the first layer computes distances from the input vector to the training input vectors and produces a vector whose elements indicate how close the input is to a training input. The second layer sums these contributions for each class of inputs to produce as its net output a vector of probabilities. Finally, a compete transfer function on the output of the second layer picks the maximum of these probabilities, and produces a 1 for that class and a 0 for the other classes. Backpropagation is a common method for training a neural network. The goal of backpropagation is to optimize the weights so that the neural network can learn how to correctly map arbitrary inputs to outputs. It also can be programmed by MATLAB. Different characteristics are input to the network and the results can be seen in Tab. 6.

**Table 6:** Results for leak detection with different characteristics

ANN type \ Characteristics	Mean value	RMS	Mean square value	Skewness	Cross correlation function	Characteristics in time-frequency domain	Accuracy of leak detection/%	False alarm rate/%
PNN	✓	✓			✓		82.22	2.18
PNN	✓	✓	✓		✓		98.89	—
BP	✓	✓	✓	✓		✓	94.29	1.36
BP	✓			✓		✓	96.67	—

In Tab. 6, the false alarm means the interfering signals are regarded as leakage signals. And it can be seen the accuracy of leak detection of PNN with mean value, RMS and cross-correlation function is only 82.22%, which is lower than that with mean value, RMS, mean square value and cross-correlation function. And the false alarm rate of the latter methods is negligible. And there is no need to input other characteristics, which can make PNN calculate fast and save leak detection time. The accuracy of leak detection of BP with mean value, RMS, mean square value, skewness and time-frequency characteristic is 94.29%, while the accuracy with mean value, skewness and time-frequency characteristic is 96.67%. And the false alarm rate of the latter methods also can be negligible. The result shows that in the network the characteristics can be influenced by each other and sometimes less characteristics causes better results.

Moreover, all characteristics extracted in this paper can be applied for leak detection, which can distinguish leakage signals from interfering signals.

## 5 Conclusions

In this paper, the acoustic method was used in leak detection and the acoustic signals were divided into background noise, leakage signal and interfering signals. The characteristics of acoustic leakage and interfering signals in time domain, frequency domain and time-frequency domain were analyzed and compared to extract the typical characteristics for leak detection, which can enhance the accuracy of the acoustic method and reduce the false alarms. The main conclusions are shown as follows:

(1) The overall kurtosis can be used to distinguish leakage signal and interfering signals. The mean value, correlation function and covariance function can be characteristics of pipe knocking signal. And Waveform and RMS of acoustic signal can distinct compressor signal and other signals. In addition, skewness, correlation function and covariance function can be adopted as the characteristics of valve switch.



(2) The energy of background noise is small and distributes widely in the entire range of frequency, while the energy of leakage and interfering signals are mainly concentrated in the low frequency bands. The leakage signal is in 0~100 Hz, compressor and valve signal are in 0~1 Hz and knocking signal is in 0~10 Hz. Therefore, the leakage signal and compressor and valve signals can be distinguished by the band of energy distribution. And a combination analysis of the time and frequency domain is required to distinct the knocking signal with other signals.

(3) The analysis of characteristics in time-frequency domain can determine the occurrence of leakage or external interference. Once a leak or external interference occurs, the amplitude of acoustic signal below 240 Hz mutates significantly, but the mutation laws vary differently with the leak condition and interfering conditions, which can be used as an auxiliary means to distinguish the leak condition and interfering conditions.

(4) Different characteristics are input to the network of PNN and BP and the results show the characteristics extracted in this paper can be applied for leak detection, which can distinguish leakage signals from interfering signals and the accuracy in our method is high and the false alarm rate is negligible.

**Acknowledgements:** This paper was funded by the National Science Foundation of China (51774313), Shandong Provincial Key R&D Program (2017GSF220007), National Key R&D Program of China (2016YFC0802104). Thanks for the permission to publish this paper.

## References

1. Pal-Stefan, M., Ioan, S. (2012). A survey on gas leak detection and localization techniques. *Journal of Loss Prevention in the Process Industries*, 25, 966-973.
2. Meng, L. Y., Li, Y. X., Wang, W. C., Fu, J. T. (2012). Experimental study on leak detection and location for gas pipeline based on acoustic method. *Journal of Loss Prevention in the Process Industries*, 25(1), 90-102.
3. Gao, Y., Brennan, M. J., Joseph, P. F., Muggleton, J. M., Hunaidi, O. (2004). A model of the correlation function of leak noise in buried plastic pipes. *Journal of Sound and Vibration*, 277, 133-148.
4. Brennan, M. J., Gao, Y., Joseph, P. F. (2007). On the relationship between time and frequency domain methods in time delay estimation for leak detection in water distribution pipes. *Journal of Sound and Vibration*, 304, 213-223.
5. Lay-Ekuakille, A., Vendramin, G., Trotta, A. (2009). Spectral analysis of leak detection in a zigzag pipeline: a filter diagonalization method-based algorithm application. *Measurement*, 42, 358-367.
6. Yang, B. W., Recance, M. (2002). Method and apparatus for pattern match filtering for real time acoustic pipeline leak detection and location. U.S. Patent 6389881B1.
7. Ye, Y. C., Zhang, L. B., Liang, W. (2010). Study of noise reduction of natural gas pipeline leakage acoustic series by local projection. *Journal of China University of Petroleum (Edition of Natural Science)*, 1, 118-124.
8. Zhu, X., Xu, Q., Tang, M. G., Fu, X. M., Zhou, J. B. (2013). Experimental study of infrasound wave generated by typical rock fracture. *Rock and Soil Mechanics*, 5, 1306-1312.
9. Lu, L., Long, Y., Zhong, M. S., Xie, Q. M., Li, X. H. (2012). Separating noise from a blasting vibration signal based on fast ICA. *Journal of Vibration and Shock*, 31(17), 33-37.
10. Li, M. S., Guo, H. D., Li, D. R. (2013). Review of vibration signal processing methods. *Chinese Journal of Scientific Instrument*, 8, 1907-1915.
11. Choon, S. P., Jong, H. J., Yang, H. K. (2014). Localization of a sound source in a noisy environment by hyperbolic curves in frequency domain. *Journal of Sound and Vibration*, 333, 5630-5640.
12. Li, S. Y., Wen, Y. M., Li, P., Yang, J., Dong, X. X. et al. (2014). Leak location in gas pipelines using cross-time-frequency spectrum of leakage-induced acoustic vibrations. *Journal of Sound and Vibration*, 333, 3889-3903.
13. Meng, L. Y., Li, Y. X., Song, L. Q., Zhao, F. S., Fu, J. T. (2010). Wave propagation characteristic of acoustic signals and leak location of gas pipeline. *Nature Gas Industry*, 30(11), 74-79.
14. Wan, H. J., Sun, L. Y., Zhang, X. W. (2009). The DOLPHIN intelligent acoustic pipeline leak monitoring

- system. *Automation Expo*, (3), 87-90.
15. Wang, D. K., Peng, J. Y. (2006). *Wavelet analysis and its application in signal processing*, pp. 24-27. Beijing: Publishing House of Electronics Industry.
  16. Chen, Y., Guan, J. (2011). Detection system of leakage in crude petroleum pipeline based on hybrid wavelet features analysis. *Journal of Petrochemical Universities*, 24(1), 89-92.
  17. Li, Z. Z. (2008). *MATLAB digital signal processing and application*, pp. 204-214. Beijing: Tsinghua University Press.
  18. Fernando, V., Surendra, P. V. (1998). Importance of skewness and kurtosis statistical tests for outlier detection and elimination in evaluation of geochemical reference materials. *Mathematical Geology*, 30(1), 109-128.
  19. Zhao, S. H. (2010). Using combined method of short-time Fourier transform and Qigner-Ville to determine instantaneous frequency of seismic signal. *Journal of Xi'an University of Science and Technology*, 30(4), 447-450.
  20. Li, Y. X., Tang, J. F., Wang, W. C. (2010). Design and construction of an experimental device for acoustic leak detection in gas pipelines. *Experimental Technology and Management*, 27(8), 63-67.
  21. Yu, D. L., Zhang, L. B., Liang, W., Liang, W., Ye, Y. C. et al. (2009). Design and development of long-distance pipeline leakage detection system. *Journal of Petrochemical Universities*, 22(2), 93-96.
  22. Du, J. X., Wang, Z. F. (2008). Plant leaf identification based on radial basis probabilistic neural network. *Pattern Recognition and Artificial Intelligence*, 21(2), 206-213.
  23. John, C. B. (2009). The FFT and Tone Identification. *Handbook of Signal Processing in Acoustics*, 53-64.
  24. Zhang, F., Shi, X. F., Zhang, X. Z. (2009) Study and simulation of welch power spectrum estimation method. *Journal of Xi'an Technological University*, 29(4), 353-356.