

An Optimized Algorithm for D2D-MIMO 5G Wireless Networks

Shahid Bashir¹, Imran Khan², Fahd N. Al-Wesabi³, Nadhem Nemri³,
Ammar Zahary⁴ and Quang Ngoc Nguyen^{5,*}

¹Department of Business Studies, Namal University, Pakistan

²Department of Electrical Engineering, University of Engineering and Technology Peshawar, Pakistan

³Department of Computer Science, King Khalid University, Muhayel Aseer, KSA

⁴Faculty of Computer and IT, Sana'a University, Sana'a, Yemen

⁵Department of Communications and Computer Engineering, Faculty of Science and Engineering,

⁶Waseda University, Shinjuku-ku, Tokyo, 169-0051, Japan

*Corresponding Author: Quang Ngoc Nguyen. Email: quang.nguyen@fuji.waseda.jp

Received: 18 January 2021; Accepted: 21 February 2021

Abstract: The device-to-device (D2D) networking technology is extended to the conventional cellular network to boost the communication efficiency of the entire network, forming a heterogeneous 5G and beyond (B5G) communication network. D2D communication in a cellular cell will boost the efficiency of the spectrum, increase the ability of the device, and reduce the communication burden of base stations through the sharing of approved cell resources, causing serious interference as well. The device-to-device (D2D) networking technology is extended to the conventional cellular network to boost the communication efficiency of the entire network, forming a heterogeneous 5G communication network. D2D communication in a cellular cell will boost the efficiency of the spectrum, increase the ability of the device, and reduce the communication burden of base stations through the sharing of approved cell resources, causing serious interference as well. This paper proposes an efficient algorithm to minimize interference, based on the parity of the number of antennas, to resolve this issue. The primary concept is to generate the cellular connection precoding matrix by minimizing the power of interference from the base station to non-targeted receivers. Then through the criterion of maximum SINR, the interference suppression matrix of the cellular connection is obtained. Finally, by removing intra-interference through linear interference alignment, the maximum degree of freedom is obtained. The results of the simulation show that the proposed algorithm efficiently increases the performance of the spectrum, decreases interference, improves the degrees of freedom and energy efficiency compared to current algorithms.

Keywords: 5G and beyond (B5G) networks; device-to-device; heterogeneous; interference; multiple-input and multiple-output



This work is licensed under a Creative Commons Attribution 4.0 International License, which permits unrestricted use, distribution, and reproduction in any medium, provided the original work is properly cited.

1 Introduction

The next generation of wireless networks has evolved in recent years towards higher data transfer speeds, better use of resources and greater network capacity, which sets higher requirements for potential wireless spectrum resources, and can meet these requirements with D2D communication technology [1–6]. Although D2D communication technology is applied in the cellular network, it also introduces intracellular interference and intercellular interference.

Therefore, the top priority of current research on this subject has been to eradicate these interferences. Currently, D2D communication interference management research focuses primarily on power control, resource scheduling, and the combination of other advanced technologies. Among them, power management is to change the transmitting power through the base station of D2D users and cellular users to ensure that the interference between cellular users and D2D users does not exceed a certain threshold [7–15]. The scheduling of resources is based on the allocation of resources by cellular users and the interference between D2D users and cellular users, so that D2D users can reasonably choose cellular users who share resources with them in order to optimize performance indicators such as the noise ratio of throughput and signal to interference. Moreover, it has also been one of the future growth trends [16–21] to merge D2D communication with other advanced technologies such as multi-antenna technology and interference synchronization.

Alignment of intervention/interference (IA) [22–27] is a technology that varies from the conventional technology of channel orthogonalization. In an interference subspace with a dimension smaller than the number of intervening users at the transmitting end, it arranges multiple interference signals and requires only to perform basic operations at the receiving end. Zero-forcing processing allows almost half of the interference-free frequency spectrum to be obtained by each user, thus essentially removing co-channel interference and improving device capability. The application of IA technology to D2D communication [28–35] is considered in some recent literature. In [28], the authors studied the scenario of heterogeneous communication in a multi-cell environment between cellular users and D2D users, and eliminated intra-cell interference and inter-cell interference by linear interference alignment technology, then gained the system's total degree of freedom (DOF). Reference [29] compared IA transmission and D2D transmission output without IA from the point of view of bit error rate and overall rate, then suggested several mechanisms for grouping D2D communication based on IA transmission. In D2D communication, [30] suggested a D2D-assisted interference alignment (DIA) model that removed inter-cell interference and inter-user interference at the two edges of the two cells in the D2D user network. In addition, given that multiple-input and multiple-output (MIMO) is a promising 5G communications technology [31], the authors in [32] have improved the energy efficiency of the D2D link and cellular link in the D2D-MIMO downlink network via IA technology, and have acquired a closed-form solution that meets the full energy efficiency of the D2D link under the condition of interference alignment. The interference issue caused by multiple D2D transmitters interacting with one D2D receiver in the D2D LAN environment was studied in the work [33]. The two interference alignment systems proposed by the authors are able to control or remove cellular connection interference and guarantee a certain level of D2D local network coverage. Reference [34] studied the transceiver's robust optimization problem and suggested an interference alignment design scheme based on semi-definite positive programming. Regarding the issue of MU-MIMO cellular network D2D user clustering and resource allocation, the authors in [35] suggested a new algorithm for interference alignment based on distance-constrained joint user clustering and allocation of resources.

The interference alignment algorithm proposed in [28] has not, however, yet solved the system's maximum degree of independence. The inter-cellular interference and the interference caused by the cellular connection to the D2D link were not thoroughly considered in [29,34]. In [30], the distributed interference alignment scheme is not ideal as D2D users switch to the middle of the cell. The effect of inter-cell interference on consumer energy efficiency was not taken into account in comparison [32] and its solution mechanism is, therefore, more complicated. The references [33,35] only considered the cellular uplink channel and did not research the downlink channel interference issue.

In answer to the above problems, in this paper, a new downlink interference alignment and a transmit end data stream allocation scheme based on the parity of the number of antennas are proposed in the D2D-MIMO interference network [25–35] to solve the interference and intra-cellular interference. The proposed algorithm successfully obtains the highest degree of independence and increases the network system's performance and flexibility. Finally, in terms of machine independence, spectrum quality, and energy efficiency, theoretical analysis and experimental simulation show that the algorithm can gain considerable performance advantages.

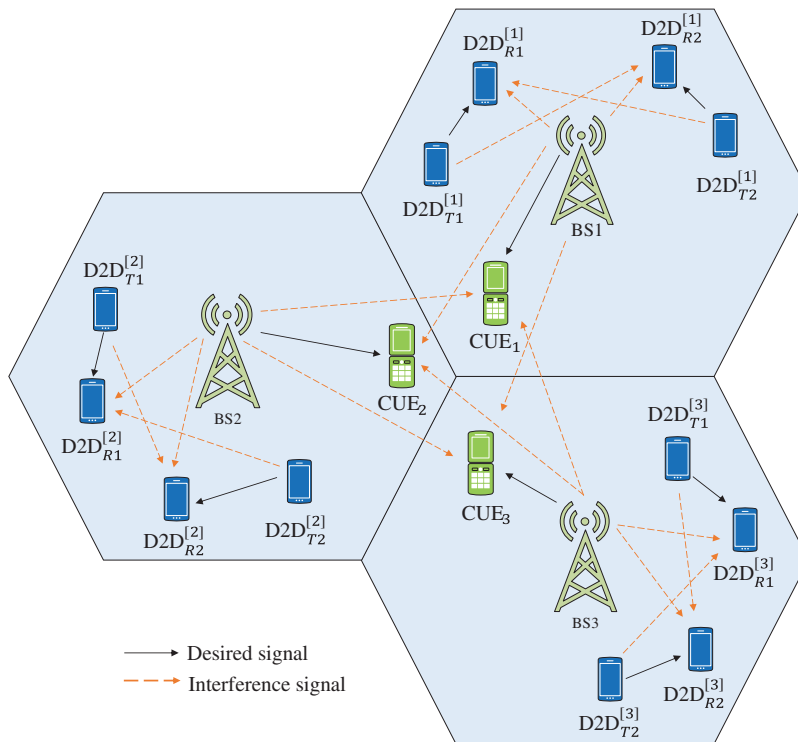

Figure 1: Proposed system model

2 System Model

This paper considers the multi-cell scenario where the number of cells $K = 3$ as shown in Fig. 1. Without loss of generality, we suppose there is a base station (BS_i) in each cell i ($i = 1, 2, \dots, K$), a cellular edge user (CEU_i) and two pairs of D2D users ($(D2D_{T_j}^{[i]}, D2D_{R_j}^{[i]}, j = 1, 2)$).

It is assumed that these K cells (including the D2D transmission links in each cell) reuse the same cellular downlink resources. Also, the number of antennas for each base station, cellular user, and D2D user is M , the channel between each transmitting and receiving pair on the same frequency at the same time is flat fading, and the channel coefficients are independent and identically distributed.

In each cell, via the power control mechanism or the D2D transmission connection selection mechanism, the interference from the D2D transmitter to the cellular link can be controlled below a certain threshold. The intra-cellular interference, therefore, occurs as the interference of the D2D transmission connection from the base station. The interference of the base station with the neighboring cell edge users [2] is the interference between the D2D transmission link and the inter-cell interference. A new interference alignment algorithm is suggested for this hybrid network of D2D communication and cellular communication and the total degree of device freedom is derived.

3 Proposed Algorithm

3.1 Inter-Cell Interference Alignment

First, consider the elimination of inter-cell interference. For the convenience of discussion, when the number of cells is K , the system model is equivalently expressed as the inter-cell interference model in K cellular networks as shown in Fig. 2.

The inter-cell interference appears as co-channel interference from the base station to the edge users of adjacent cells. The \mathbf{H}_{ii} and \mathbf{H}_{ij} denotes the channel matrix between BS_i and CUE_i , CUE_j ($i, j \in \{1, 2, \dots, K\}$, $i \neq j$). Suppose the number of independent data streams sent by the base station BS_i is d_i and the condition $d_1 = d_2 = \dots = d_i$ is met. On a specific time-frequency resource, the received signal of CUE_i can be expressed as

$$\mathbf{y}_i = \mathbf{H}_{ii} \mathbf{V}_i \mathbf{s}_i + \sum_{j=1, j \neq i}^K \mathbf{H}_{ji} \mathbf{V}_j \mathbf{s}_j + \mathbf{n}_i \quad (1)$$

where \mathbf{V}_i with dimension $M \times d_i$ and \mathbf{V}_j with dimension $M \times d_j$ are BS_i and BS_j , respectively, corresponding to the precoding matrices of CUE_i and CUE_j , and satisfy $\mathbf{V}_i^H \mathbf{V}_i = \mathbf{I}_{d_i}$, $\mathbf{V}_j^H \mathbf{V}_j = \mathbf{I}_{d_j}$; \mathbf{s}_i with the dimension $d_i \times 1$ is the downlink data vector signal of BS_i , and it satisfies the power constraint $E[\mathbf{s}_i^H \mathbf{s}_i] = \mathbf{P}(i)$; \mathbf{n}_i with dimension $M \times 1$ is the additive white Gaussian noise with mean 0 and variance 1, and $E[\mathbf{n}_i \mathbf{n}_i^H] = \mathbf{I}_M$.

The purpose of interference alignment is to enable the target signal to be put into the signal subspace of dimension d_i without interference, and to put the interference signals from other base stations into the interference subspace of dimension $M - d_i$. Therefore, the signal of the user CUE_i at the receiving end after being processed by the interference suppression matrix of dimension $M \times d_i$ is expressed as

$$\tilde{\mathbf{y}}_i = \mathbf{U}_i^H \mathbf{H}_{ii} \mathbf{V}_i \mathbf{s}_i + \sum_{j=1, j \neq i}^K \mathbf{U}_i^H \mathbf{H}_{ji} \mathbf{V}_j \mathbf{s}_j + \mathbf{U}_i^H \mathbf{n}_i \quad (2)$$

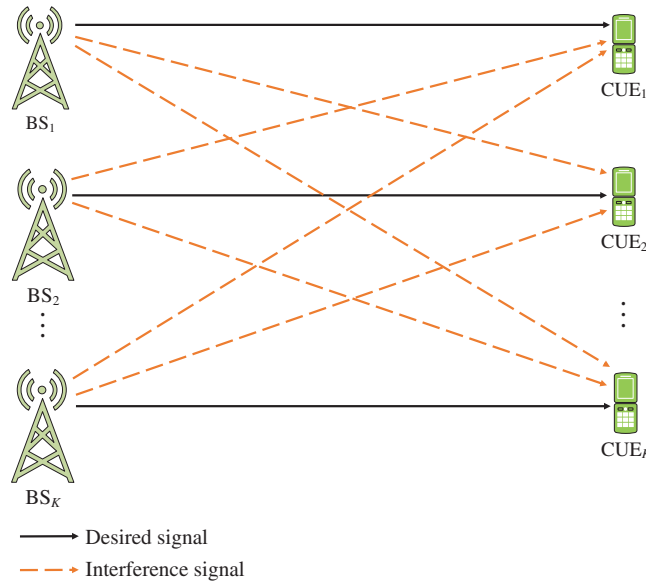

Figure 2: Inter-cell interference model

where $\mathbf{U}_i^H \mathbf{U}_i = \mathbf{I}_{d_i}$, $\mathbf{U}_j^H \mathbf{U}_j = \mathbf{I}_{d_j}$, and the constraints that should be met under the condition of a high signal-to-noise ratio are

$$\begin{cases} \mathbf{U}_i^H \mathbf{H}_{ji} \mathbf{V}_j = 0, & \forall j \neq i \\ \text{rank}(\mathbf{U}_i^H \mathbf{H}_{ii} \mathbf{V}_i) = d_i \end{cases} \quad (3)$$

The SINR of the l th data stream of the receiving user CUE_i can be expressed as

$$\text{SINR}_{il} = \frac{\mathbf{U}_{il}^H \mathbf{H}_{ii} \mathbf{V}_{il} \mathbf{V}_{il}^H \mathbf{U}_{il}^H \mathbf{U}_{il}}{\mathbf{U}_{il}^H \mathbf{B}_{il} \mathbf{U}_{il}} \times \frac{P(i)}{d_i}, \quad \forall i \in \{1, 2, \dots, K\}, \quad \forall l \in \{1, 2, \dots, d_i\} \quad (4)$$

where the numerator represents the signal power of the first data stream of the receiving end-user CUE_i after interference suppression, and the denominator is the total power of noise plus interference; \mathbf{B}_{il} is defined as the interference plus noise covariance matrix.

In order to eliminate the inter-cell interference, the next step is to obtain the optimal precoding matrix \mathbf{V}_i and interference suppression matrix \mathbf{U}_i .

First, for the receiving end-user CUE_i , by maximizing the SINR of the receiving end-user CUE_i to obtain \mathbf{U}_i , the following optimization problem can be obtained

$$\begin{aligned} & \max (\text{SINR}_{il}) \\ & \text{subject to} \\ & \begin{cases} E[s_i^H s_i] = P(i) \\ \text{rank}(\mathbf{U}_i^H \mathbf{H}_{ii} \mathbf{V}_i) = d_i \\ \mathbf{U}_i^H \mathbf{U}_i = \mathbf{I}_{d_i} \end{cases} \end{aligned} \quad (5)$$

For this optimization problem, the unitized column vector of the interference suppression matrix that maximizes the SINR is

$$\mathbf{U}_{il} = \frac{(\mathbf{B}_{il})^{-1} \mathbf{H}_{ii} \mathbf{V}_{il}}{\|(\mathbf{B}_{il})^{-1} \mathbf{H}_{ii} \mathbf{V}_{il}\|} \quad (6)$$

From Eq. (6), the interference suppression matrix \mathbf{U}_i can be obtained as

$$\mathbf{U}_i = [\mathbf{U}_{i1}, \mathbf{U}_{i2}, \dots, \mathbf{U}_{il}, \dots, \mathbf{U}_{id_i}] \quad (7)$$

Secondly, for the transmitter base station BS_i , this paper solves the precoding matrix \mathbf{V}_i by minimizing the signal power of the base station BS_i leaked to non-target users, while taking into account the transmit power constraint $E[s_i^H s_i] = \mathbf{P}(i)$, the following optimization problem is obtained

$$\min E \left\| \left(\sum_{j=1, j \neq i}^K \mathbf{U}_j^H \mathbf{H}_{ij} \right) \mathbf{V}_i s_i \right\|_{\text{F}}^2$$

subject to

$$\begin{cases} E[s_i^H s_i] = \mathbf{P}(i) \\ \text{rank}(\mathbf{U}_i^H \mathbf{H}_{ii} \mathbf{V}_i) = d_i \\ \mathbf{V}_i^H \mathbf{V}_i = \mathbf{I}_{d_i} \end{cases} \quad (8)$$

For the optimization problem in Eq. (8), the precoding matrix \mathbf{V}_i of the base station BS_i at the transmitting end can be obtained by Eq. (9) as

$$\mathbf{V}_i^{\text{opt}} = \arg \min_{\mathbf{V}_i^H \mathbf{V}_i = \mathbf{I}_{d_i}} \min E \left\| \left(\sum_{j=1, j \neq i}^K \mathbf{U}_j^H \mathbf{H}_{ij} \right) \mathbf{V}_i s_i \right\|_{\text{F}}^2 \quad (9)$$

From the matrix theory, it can be known that finding the Frobenius norm of the above matrix is to find the trace of the matrix covariance, and the Eq. (9) is equivalent to

$$\mathbf{V}_i^{\text{opt}} = \arg \min_{\mathbf{V}_i^H \mathbf{V}_i = \mathbf{I}_{d_i}} \text{mintr} \left(\mathbf{V}_i^H \left(\sum_{i=1, i \neq j}^K \mathbf{H}_{ij}^H \mathbf{U}_j \mathbf{U}_j^H \mathbf{H}_{ij} \right) \mathbf{V}_i \right) \quad (10)$$

Therefore, the optimal precoding matrix \mathbf{V}_i is composed of the eigenvectors corresponding to the d_i smallest eigenvalues of the term in Eq. (10) which is expressed as

$$\mathbf{V}_i^{\text{opt}} = \mathbf{v}_{\min}^{d_i} \left(\sum_{i=1, i \neq j}^K \mathbf{H}_{ij}^H \mathbf{U}_j \mathbf{U}_j^H \mathbf{H}_{ij} \right) \quad (11)$$

According to Eq. (11), for the receiving end-user CUE_i and the transmitting end base station BS_i , the process of obtaining the proposed hybrid algorithm is shown in Algorithm 1.

Algorithm 1: Inter-cell interference alignment

Initialize: Precoding matrix V_i

- 1: Calculate $U_i, \forall i \in \{1, 2, \dots, K\}$ from Eqs. (5)–(7)
 - 2: Unitize U_i
 - 3: Substitute U_i into Eq. (11) and calculate $V_i, \forall i \in \{1, 2, \dots, K\}$
 - 4: Repeat Steps 1 and 3 until obtaining convergence
-

3.2 Intra-Cellular Interference Alignment

The problem of inter-cell interference is successfully solved via the above-mentioned inter-cell interference alignment algorithm. The intra-cell interference manifests itself here as the interference between the base station and the transmission connection of the D2D and the interference between the transmission connections of the D2D. We take Cell 1 as an example to explore the solution of intra-cell interference alignment without loss of generality. To minimize intra-cellular interference, this paper utilizes linear interference alignment and proposes a data stream allocation scheme based on the parity of the number of antennas at the transmitting end. Because Max-SINR parameters can be obtained by the interference suppression matrix at the receiving end, the following emphasis is on the precoding matrix and distribution of the data stream at the transmitting end. Fig. 3 shows the system model of intra-cellular interference in K cellular networks. Among them, $G_{11}^{[1]}$ and $G_{12}^{[1]}$ with dimension $M \times M$ respectively represent the channel matrix between $D2D_{T1}^{[1]}$ and $D2D_{R1}^{[1]}$ and $D2D_{R2}^{[1]}$; $G_{21}^{[1]}$ and $G_{22}^{[1]}$ of dimension $M \times M$ respectively represent the channel matrix between $D2D_{T2}^{[1]}$ and $D2D_{R1}^{[1]}$, $D2D_{R2}^{[1]}$; $F_{11}^{[1]}$ and $F_{12}^{[1]}$ with dimension $M \times M$ respectively represent the channel matrix between BS_1 and $D2D_{R1}^{[1]}$ and $D2D_{R2}^{[1]}$.

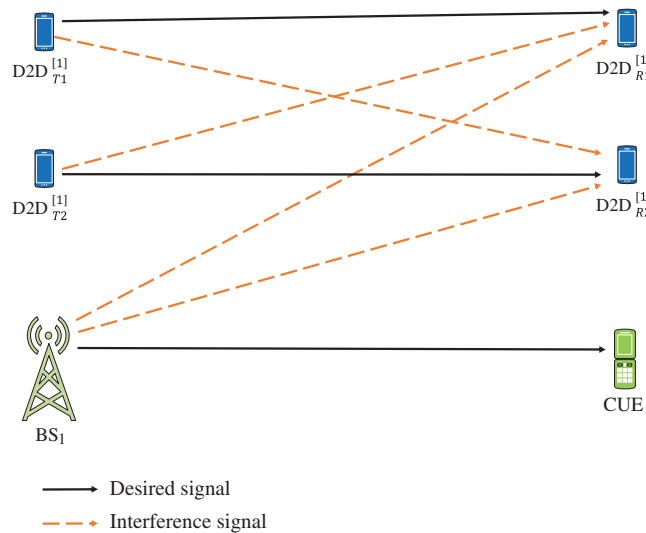

Figure 3: Intra-cell interference model

Let the number of independent data streams sent by $D2D_{T1}^{[1]}$ and $D2D_{T2}^{[1]}$ be $d_1^{[1]}$ and $d_2^{[1]}$ respectively, and d_1 , is the number of independent data streams sent by the base station BS_1 .

$\mathbf{D}_1^{[1]}$ and $\mathbf{D}_2^{[1]}$ are the precoding matrices of the transmitters $\text{D2D}_{T1}^{[1]}$ and $\text{D2D}_{T2}^{[1]}$, respectively, and their dimensions are $M \times d_1^{[1]}$ and $M \times d_2^{[1]}$. When the number of antennas M of the base station, cellular users and D2D users is odd (greater than 1), let BS_1 , $\text{D2D}_{T1}^{[1]}$, $\text{D2D}_{T2}^{[1]}$ send the number of independent data streams respectively: $d_1 = (M-1)/2$, $d_1^{[1]} = (M-1)/2$, $d_2^{[1]} = (M+1)/2$. Because $d_1 = d_2 = \dots = d_K \leq M/2$, through the inter-cell interference alignment, the degree of freedom of each base station is $(M-1)/2$, the dimension of the precoding matrix \mathbf{V}_1 of BS_1 is $M \times (M-1)/2$, and the interference suppression of CUE_1 with a dimension of the matrix \mathbf{U}_1 is $M \times (M-1)/2$. By aligning the interference signals received by $\text{D2D}_{R1}^{[1]}$ and $\text{D2D}_{R2}^{[1]}$, we can get

$$\begin{cases} \text{span}(\mathbf{F}_{11}^{[1]} \mathbf{V}_1) \subset \text{span}(\mathbf{G}_{21}^{[1]} \mathbf{D}_2^{[1]}) \\ \text{span}(\mathbf{F}_{12}^{[1]} \mathbf{V}_1) \subset \text{span}(\mathbf{G}_{12}^{[1]} \mathbf{D}_1^{[1]}) \end{cases} \quad (12)$$

In Eq. (12), because $\dim(\mathbf{F}_{12}^{[1]} \mathbf{V}_1) = \dim(\mathbf{G}_{12}^{[1]} \mathbf{D}_1^{[1]}) = (M-1)/2$, the second row can be equivalent to

$$\mathbf{D}_1^{[1]} = (\mathbf{G}_{12}^{[1]})^{-1} \mathbf{F}_{12}^{[1]} \mathbf{V}_1 \quad (13)$$

The precoding matrix \mathbf{V}_1 of BS_1 has been successfully obtained by the inter-cell interference alignment described above, so the precoding matrix $\mathbf{D}_1^{[1]}$ of the transmitting end $\text{D2D}_{T1}^{[1]}$ can be directly calculated by Eq. (13). Because the rank $(\mathbf{D}_2^{[1]}) = (M+1)/2$, so it can be divided into two parts $\mathbf{D}_2^{[1]} = [\mathbf{D}_{21}^{[1]}, \mathbf{D}_{22}^{[1]}]$. Among them, $\mathbf{D}_{21}^{[1]} \cap \mathbf{D}_{22}^{[1]} = \emptyset$ and $\text{rank}(\mathbf{D}_{21}^{[1]}) = (M-1)/2$, $\text{rank}(\mathbf{D}_{22}^{[1]}) = 1$. To ensure that $\mathbf{D}_{21}^{[1]}$ and $\mathbf{D}_{22}^{[1]}$ are independent of each other, $\mathbf{D}_{22}^{[1]}$ can be formed by the orthogonal space vector of $\mathbf{D}_{21}^{[1]}$, namely $\mathbf{D}_{22}^{[1]} \subset \mathbf{D}_{21}^{[1]}$.

$\mathbf{D}_{21}^{[1]}$ can be obtained directly by $\text{span}(\mathbf{F}_{11}^{[1]} \mathbf{V}_1) = \text{span}(\mathbf{G}_{21}^{[1]} \mathbf{D}_2^{[1]})$: $\mathbf{D}_{21}^{[1]} = (\mathbf{G}_{12}^{[1]})^{-1} \mathbf{F}_{12}^{[1]} \mathbf{V}_1$, that is, through the intracellular interference alignment system, the transmitter $\text{D2D}_{T1}^{[1]}$ and $\text{D2D}_{T2}^{[1]}$ precoding can be successfully solved Matrix $\mathbf{D}_1^{[1]}$ and $\mathbf{D}_2^{[1]}$.

When the number of antennas M of the base station, cellular user and D2D user is even, let for BS_1 , the $\text{D2D}_{T1}^{[1]}$, and $\text{D2D}_{T2}^{[1]}$ are the number of independent data streams sent respectively: $d_1 = M/2$, $d_1^{[1]} = M/2$, $d_2^{[1]} = M/2$. Since $d_1 = d_2 = \dots = d_K = M/2$, through inter-cell interference alignment, the degree of freedom of each base station is $M/2$, and the dimensions of the precoding matrix \mathbf{V}_1 of BS_1 and the interference suppression matrix \mathbf{U}_1 of CUE_1 are both $M \times M/2$. By aligning the interference signals received by $\text{D2D}_{R1}^{[1]}$ and $\text{D2D}_{R2}^{[1]}$, we can get

$$\begin{cases} \text{span}(\mathbf{F}_{11}^{[1]} \mathbf{V}_1) = \text{span}(\mathbf{G}_{21}^{[1]} \mathbf{D}_2^{[1]}) \\ \text{span}(\mathbf{F}_{12}^{[1]} \mathbf{V}_1) = \text{span}(\mathbf{G}_{12}^{[1]} \mathbf{D}_1^{[1]}) \end{cases} \quad (14)$$

where $\dim(\mathbf{F}_{11}^{[1]}\mathbf{V}_1) = \dim(\mathbf{G}_{21}^{[1]}\mathbf{D}_2^{[1]}) = M/2$, $\dim(\mathbf{F}_{12}^{[1]}\mathbf{V}_1) = \dim(\mathbf{G}_{12}^{[1]}\mathbf{D}_1^{[1]}) = M/2$, Eq. (14) is equivalent to

$$\begin{cases} \mathbf{D}_2^{[1]} = (\mathbf{G}_{21}^{[1]})^{-1} \mathbf{F}_{11}^{[1]}\mathbf{V}_1 \\ \mathbf{D}_1^{[1]} = (\mathbf{G}_{12}^{[1]})^{-1} \mathbf{F}_{12}^{[1]}\mathbf{V}_1 \end{cases} \quad (15)$$

When the number of antennas M of the base station, cellular users and D2D users is even, the transmitter $\text{D2D}_{T1}^{[1]}$ and $\text{D2D}_{T2}^{[1]}$ precoding matrices are $\mathbf{D}_1^{[1]}$ and $\mathbf{D}_2^{[1]}$.

According to the derivation of the above expression, the algorithm flow for obtaining intra-cellular interference alignment is shown in Algorithm 1.

Algorithm 2: Intra-cell interference alignment

- 1: Determine the parity of the number of antennas M
 - 2: Select the corresponding data stream of the corresponding at the transmitting end
 - 3: Obtain the precoding matrixes $\mathbf{D}_1^{[i]}$ and $\mathbf{D}_2^{[i]}$ of $\text{D2D}_{T1}^{[i]}$ and $\text{D2D}_{T2}^{[i]}$, $\forall i \in \{1, 2, \dots, K\}$
 - 4: Calculate the interference suppression matrix of $\text{D2D}_{R1}^{[i]}$ and $\text{D2D}_{R2}^{[i]}$, $\forall i \in \{1, 2, \dots, K\}$ at the receiving end from Eqs. (5)–(7)
-

4 System Freedom and Complexity Analysis

Since the number of independent data streams sent by the base station and D2D users is related to the number of antennas, due to the parity of the number of antennas, the system's degree of freedom is also studied separately. When the number of antennas M of the base station, cellular user and D2D user is odd (greater than 1), the number of independent data streams sent by BS_i , $\text{D2D}_{T1}^{[i]}$, $\text{D2D}_{T2}^{[i]}$ are $d_i = (M-1)/2$, $d_1^{[i]} = (M-1)/2$, $d_2^{[i]} = (M+1)/2$ ($i \in \{1, 2, \dots, K\}$). Through the inter-cell interference alignment, the degree of freedom obtained by each cellular link is $(M-1)/2$; Through intra-cell interference alignment, in each cell, the sum of the degrees of freedom obtained by two D2D links is always M . Therefore, the degree of freedom that a single cell can achieve is $\text{DOF}_{\text{single}} = M + (M-1)/2$, which has nothing to do with the number of cells K , so the total degree of freedom of K cells systems is $\text{DOF}_K = K \cdot (M + (M-1)/2)$.

Similarly, when the number of antennas M of the base station, cellular user and D2D user is even, the number of independent data streams sent by BS_i , $\text{D2D}_{T1}^{[i]}$, $\text{D2D}_{T2}^{[i]}$ are $d_i = (M)/2$, $d_1^{[i]} = M/2$, $d_2^{[i]} = M/2$ ($i \in \{1, 2, \dots, K\}$). At this time, the degree of freedom that a single cell can achieve is $\text{DOF}_{\text{single}} = 3M/2$, and the total degree of freedom of the K honeycomb system is $\text{DOF}_K = K \cdot 3M/2$. For the QK algorithm in [9], when the number of cells is 3, the degree of freedom of a single cell is $\text{DOF}_{\text{single}} = M + M/3$; When the number of cells is K , the degree of freedom of a single cell is $\text{DOF}_{\text{single}} = M + M/K$, and the number of antennas M must be a multiple of the number of cells K . For the ML algorithm in [14], if the inter-cell interference is considered, the degree of freedom of a single cell when the number of cells is K is $\text{DOF}_{\text{single}} = M + M/K$. When the interference of the base station to the D2D link is further considered, the signal subspace of the D2D receiving end will be affected by the interference

from the base station, so the single-cell degree of freedom when the number of cells is K is $DOF_{\text{single}} < M + M/K$.

Compared to the QK algorithm [28] and the ML algorithm [34], the proposed algorithm proposes a scheme of allocation of data streams based on the parity of the number of M antennas and a scheme-based algorithm of interference alignment, which increases the degree of freedom, improves the system's flexibility and expands the system's capacity. Considering the inter-cell interference and intra-cell interference, if and only when the number of cells $K = 3$ and the number of antennas $M = 3$, the system degrees of freedom obtained by the proposed algorithm and the QK algorithm are equal (both are 12). In other cases, the degree of freedom of the system obtained by the proposed algorithm is significantly higher than that of the QK algorithm. At the same time, the system degree of freedom obtained by the QK algorithm is always higher than that of the ML algorithm, that is, the proposed algorithm is also better than the ML algorithm.

The system's complexity analysis is as follows: Since the QK algorithm solves inter-cell interference and intra-cell interference by linear interference alignment, when eliminating inter-cell interference, the suggested algorithm uses hybrid iterative interference alignment. The individual value of the (10) term corresponding feature vector is needed for each iteration, so the complexity of the proposed algorithm is greater than that of the QK algorithm, i.e., the proposed algorithm sacrifices part of the complexity in order to obtain better machine efficiency via an iterative interference alignment scheme based on positive semi-definite programming, the ML algorithm removes multiple co-channel interferences in the method and each iteration needs to solve a more complex problem of semi-definite convex optimization. The complexity of the ML algorithm is also higher in comparison with the proposed algorithm.

5 Simulation Results

To simulate the performance of average spectrum efficiency and average energy efficiency, we use MATLAB in this section. Taking the number of cells $K = 3$ as an example, and compared the proposed algorithm with the algorithms in [28,34]. The performance difference when the number of antennas of D2D users is $M = 3$ and $M = 6$. In the simulation, not only the path loss of cellular users and D2D users is considered, but also the shadow fading of cellular link and D2D link is calculated, and the channel matrix elements are assumed to be independent and identically distributed, and all satisfy the complex Gaussian random with mean 0 and variance 1. The remaining simulation parameters are shown in Tab. 1.

5.1 Average Spectral Efficiency

Fig. 4 shows the average spectral efficiency with D2D user-to-distance (that is, the distance from $D2D_{Tx}$ to $D2D_{Rx}$) when the D2D transmit power is 17 dBm. It is clear that no matter for $M = 3$ or $M = 6$, the algorithm [28] is better than [34]. This is because when considering both intra-cell interference and inter-cell interference, the design based on the algorithm [34]. $D2D_{Rx}$ will still be interfered by cellular links, and cellular users will still be interfered by neighboring cellular base stations, and its system degree of freedom is lower than that obtained by the QK algorithm. When $M = 3$, the degree of freedom obtained by the proposed algorithm is the same as the reference [28] algorithm, but because the proposed algorithm uses the Max-SINR criterion when solving the inter-cell and intra-cell interference suppression matrix, it is better than the zero-forcing criterion of the reference [28] algorithm. The performance of the proposed algorithm is slightly better than the algorithm in [28]. When $M = 6$, the degree of freedom provided by the proposed algorithm is clearly greater than the degree of freedom provided by the algorithm

in [26], and when the distance between the D2D users increases, the performance of the proposed algorithm is more superior. This is because the proposed algorithm first solves the problem of interference between cells, maximizes the freedom of cellular users, and adopts a more reasonable and effective data stream distribution scheme at the transmitter. When the distance between $D2D_{Tx}$ and $D2D_{Rx}$ is 80 m, compared with the algorithm in [28], the average spectral efficiency of the proposed algorithm is increased by about 25.6%, which further improves the quality of D2D communication under low and medium signal-to-noise ratios.

Table 1: Simulation parameters

Parameter	Value
The maximum distance of the D2D pair	80 m
Cell radius	250 m
The base station transmitting power	43 dBm
Path loss model of D2D link	$148 + 40 \log_{10}(d \text{ [km]})$
Path loss model of cellular link	$128.1 + 37.6 \log_{10}(d \text{ [km]})$
Shadow effect standard deviation	The cellular link is 10 dB D2D link is 12 dB
Noise spectral density	-174 dBm/Hz
Resource bandwidth	10 MHz
Noise figure	9 dB

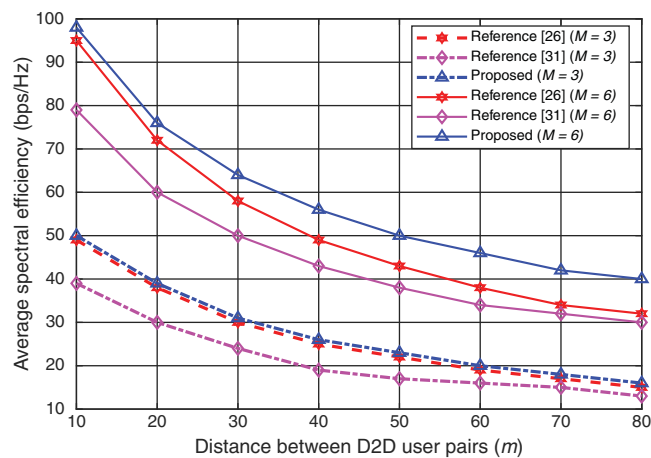

Figure 4: Average spectral efficiency comparison of the algorithms with increasing distance between D2D user pairs

As shown in Fig. 5, when the D2D user-pair distance is 20 m, as the D2D user’s transmit power gradually increases, the average spectrum efficiency is gradually improved. Regardless of the number of antennas of base stations, cellular users and D2D users, $M = 3$ or $M = 6$, the proposed algorithm is better than references [28,34] algorithms. This is because under the same D2D transmit power, the system capacity obtained by the proposed algorithm is the largest.

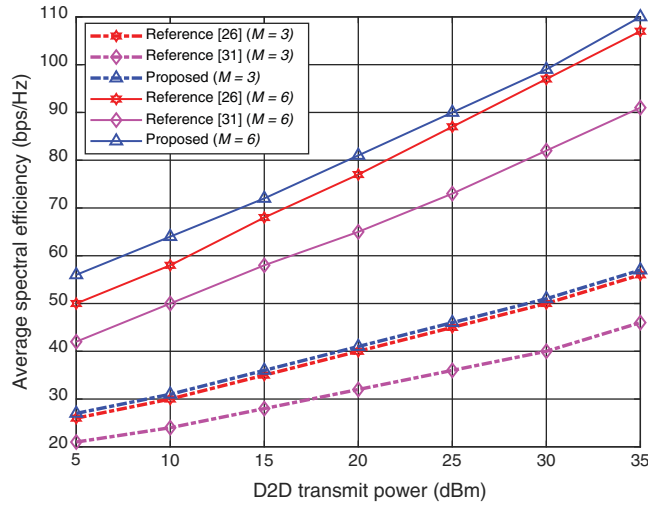

Figure 5: Average spectral comparison of the algorithms when the distance between the D2D user pair is 20 m

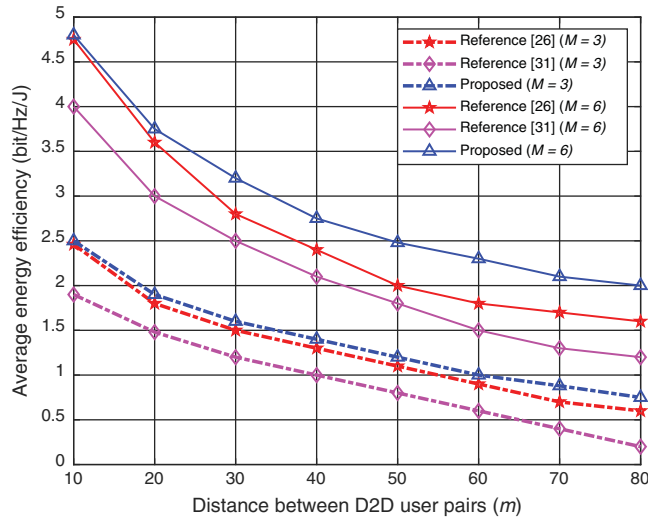

Figure 6: Average energy efficiency comparison of the algorithms with increasing distance between the D2D user pairs

5.2 Average Energy Efficiency

The average energy efficiency is defined as the number of information bits that can be transmitted per energy unit in a unit of bandwidth, and its unit is bit/Hz/J. The average energy efficiency can be expressed as:

$$EE_{average} = \frac{1}{K} \sum_{i=1}^K \frac{R_{D2D_1[i]} + R_{D2D_2[i]} + R(i)}{P_{D2D_1[i]} + P_{D2D_2[i]} + P(i)} \quad (16)$$

where $R_{D2D_1[i]}$, $R_{D2D_2[i]}$, $R(i)$ respectively represent the rate of the first D2D link, the second D2D link and the cellular link in the i th cell (unit: bit/s/Hz). The $P_{D2D_1[i]}$, $P_{D2D_2[i]}$ and $P(i)$ respectively represent the transmitting end power of the corresponding link in the i th cell.

It can be seen from Fig. 6 that with the increase of the D2D pair distance, the average energy efficiency also decreases, but the proposed algorithm can still improve the average energy efficiency of the system to a certain extent. Fig. 7 shows the average energy efficiency versus D2D user transmit power when the distance is 20 m. When the D2D transmit power is increased from 5 to 35 dBm, the average energy efficiency of the system reaches its maximum value at 29 dBm. In Fig. 7, the performance of [28,34] algorithms are worse than the proposed algorithm.

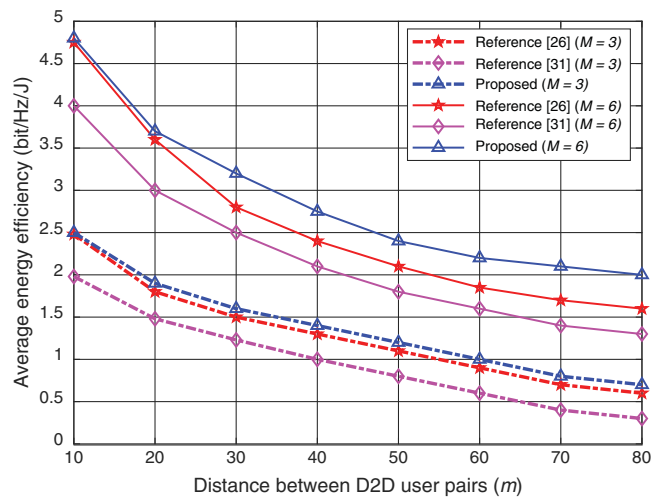

Figure 7: Average energy efficiency comparison of the algorithms when the distance between the D2D user pairs is 20 m

6 Conclusion

The problem of both inter-cell interference and intra-cell interference in the D2D-MIMO interference network is studied in this paper. This research suggests a data stream allocation scheme based on the parity of the number of antennas at the transmitting end to remove these co-channel interferences. The inter-cell interference problem is first solved via the interference alignment process, and then the intra-cell co-channel interference is removed. The full degree of the system’s independence is reached. It can be seen from the results of the simulation that, compared to the current algorithms, the proposed algorithm increases the system’s degree of freedom, spectrum performance, and energy efficiency, decreases the number of antennas needed, and extends the system’s application range.

As an addition to this study, future work is to discuss the Quality of Service (QoS) and other significant factors in wireless D2D-MIMO networks. Also, for potential future work, given that there is a rapidly growing number of interconnected devices and it would be infeasible to minimize the interferences among the billions of IoT (Internet of Things) devices in a reasonable period using classical computing, we intend to apply the idea of this study using Digital Annealer (DA) [36], a quantum-inspired technology with fully coupled bit connectivity based on the concept of Simulated Annealing, to achieve high performance with energy efficiency

and minimized inter- and intra-interferences at the same time towards sustainable B5G and 6G communication networks.

Acknowledgement: The authors would like to thank the reviewers and editors for their review and recommendations. Fahd N. Al-Wesabi extends his appreciation to the Deanship of Scientific Research at King Khalid University for supporting this work under Grant Number (RGP.2/23/42), www.kku.edu.sa.

Funding Statement: This study is funded by Fujitsu-Waseda Digital Annealer FWDA Research Project and Fujitsu Co-Creation Research Laboratory at Waseda University (Joint Research between Waseda University and Fujitsu Lab). The study was also partly supported by the School of Fundamental Science and Engineering, Faculty of Science and Engineering, Waseda University, Japan.

Conflicts of Interest: The authors declare that they have no conflicts of interest to report regarding the present study.

References

- [1] M. Waqas, Y. Niu, Y. Li, M. Ahmed, D. Jin *et al.*, “A comprehensive survey on mobility-aware D2D communications: Principles, practice and challenges,” *IEEE Communications Surveys & Tutorials*, vol. 22, no. 3, pp. 1863–1886, 2020.
- [2] M. Ahmed, Y. Li, M. Waqas, M. Sheraz, D. Jin *et al.*, “A survey on socially aware device-to-device communications,” *IEEE Communications Surveys & Tutorials*, vol. 20, no. 3, pp. 2169–2197, 2018.
- [3] F. S. Shaikh and R. Wismuller, “Routing in multi-hop cellular device-to-device (D2D) networks: A survey,” *IEEE Communications Surveys & Tutorials*, vol. 22, no. 3, pp. 2622–2657, 2018.
- [4] M. Haus, M. Waqas, A. Y. Ding, Y. Li, S. Tarkoma *et al.*, “Security and privacy in device-to-device (D2D) communication: A review,” *IEEE Communications Surveys & Tutorials*, vol. 19, no. 2, pp. 1054–1079, 2017.
- [5] O. Hayat, R. Ngah, S. Z. M. Hashim, M. H. Dahri, R. F. Malik *et al.*, “Device discovery in D2D communication: A survey,” *IEEE Access*, vol. 7, pp. 131114–131134, 2019.
- [6] Q. N. Nguyen, M. Arifuzzaman, K. Yu and T. Sato, “A context-aware green information-centric networking model for future wireless communications,” *IEEE Access*, vol. 6, pp. 22804–22816, 2018. <https://doi.org/10.1109/ACCESS.2018.2828462>.
- [7] A. Asadi, Q. Wang and V. Mancuso, “A survey on device-to-device communication in cellular networks,” *IEEE Communications Surveys & Tutorials*, vol. 16, no. 4, pp. 1801–1819, 2014.
- [8] B. M. Elhalawany, R. Ruby and K. Wu, “D2D communication for enabling internet-of-things: Outage probability,” *IEEE Transactions on Vehicular Technology*, vol. 68, no. 3, pp. 2332–2345, 2019.
- [9] I. Loannou, V. Vassiliou, C. Christophorou and A. Pitsillides, “Distributed artificial intelligence solution for D2D communication in 5G networks,” *IEEE Systems Journal*, vol. 14, no. 3, pp. 4232–4241, 2020.
- [10] P. Pawar, A. Trivedi and M. K. Mishra, “Outage and ASE analysis for power controlled D2D communication,” *IEEE Systems Journal*, vol. 14, no. 2, pp. 2269–2280, 2020.
- [11] S. Bashir, M. H. Alsharif, I. Khan, M. A. Albreem, A. Sali *et al.*, “MIMO-Terahertz in 6G nano-communications: Channel modeling and analysis,” *Computers, Materials & Continua*, vol. 66, no. 1, pp. 263–274, 2020.
- [12] A. Amin, X. Liu, I. Khan, P. Uthansakul, M. Forsat *et al.*, “A robust resource allocation scheme for device-to-device communications based on Q-learning,” *Computers, Materials & Continua*, vol. 65, no. 2, pp. 1487–1505, 2020.
- [13] S. Alemaishat, O. A. Saraereh, I. Khan, S. H. Affes, X. Li *et al.*, “An efficient precoding scheme for millimeter-wave massive MIMO systems,” *Electronics*, vol. 8, no. 9, pp. 1–15, 2019.

- [14] A. Al-Nimrat, M. Smadi, O. A. Saraereh and I. Khan, "An efficient channel estimation scheme for mmwave massive MIMO systems," in *Proc. IEEE Int. Conf. on Communication, Networks and Satellite*, Makassar, Indonesia, pp. 1–8, 2019.
- [15] I. Khan and D. Singh, "Efficient compressive sensing based sparse channel estimation for 5G massive MIMO systems," *AEU-International Journal of Electronics and Communications*, vol. 89, no. 2, pp. 181–190, 2018.
- [16] A. Amin, X. H. Liu, M. A. Saleem, S. Henna, T. Islam *et al.*, "Collaborative wireless power transfer in wireless rechargeable sensor networks," *Wireless Communications and Mobile Computing*, vol. 9701531, no. 9, pp. 1–13, 2020.
- [17] F. Jameel, T. Ristaniemi, I. Khan and B. M. Lee, "Simultaneous harvest-and-transmit ambient backscatter communications under Rayleigh fading," *EURASIP Journal on Wireless Communications and Networking*, vol. 19, no. 1, pp. 1–9, 2019.
- [18] W. Shahjehan, S. Bashir, S. L. Mohammed, A. B. Fakhri, A. A. Isaiyah *et al.*, "Efficient modulation scheme for intermediate relay-aided IoT networks," *Applied Sciences*, vol. 10, no. 6, pp. 1–12, 2020.
- [19] O. A. Saraereh, A. Alsaraira, I. Khan and B. J. Choi, "A hybrid energy harvesting design for on-body internet-of-things (IoT) networks," *Sensors*, vol. 20, no. 2, pp. 1–14, 2020.
- [20] T. Jabeen, Z. Ali, W. U. Khan, F. Jameel, I. Khan *et al.*, "Joint power allocation and link selection for multi-carrier buffer aided relay network," *Electronics*, vol. 8, no. 6, pp. 1–15, 2019.
- [21] S. Alemaishat, O. A. Saraereh, I. Khan and B. J. Choi, "An efficient resource allocation algorithm for D2D communications based on noma," *IEEE Access*, vol. 7, pp. 120238–120247, 2019.
- [22] V. R. Cadambe and S. A. Jafar, "Interference alignment and the degree of freedom for the K user interference channel," *IEEE Transactions on Information Theory*, vol. 54, no. 8, pp. 3425–3441, 2008.
- [23] E. A. Omar, W. Steven and W. Robert, "The practical challenges of interference alignment," *IEEE Wireless Communications*, vol. 20, no. 1, pp. 35–42, 2013.
- [24] K. Gomadam, V. R. Cadambe and S. A. Jafar, "Approaching the capacity of wireless networks through distributed interference alignment," in *IEEE Global Communications Conf.*, New Orleans, USA, pp. 1–6, 2008.
- [25] R. Tandon, S. Mohajer, H. V. Poor and S. Shamai, "Degrees of freedom region of the MIMO interference channel with output feedback and delayed CSIT," *IEEE Transactions on Information Theory*, vol. 59, no. 3, pp. 1444–1457, 2013.
- [26] Y. Abdulkadir, O. Simpson and Y. Sun, "Interference alignment for cognitive radio communications and networks: A survey," *Journal of Sensors and Actuator Networks*, vol. 8, no. 4, pp. 1–33, 2019.
- [27] F. Qamar *et al.*, "Issues, challenges, and research trends in spectrum management: A comprehensive overview and new vision for designing 6G networks," *Electronics*, vol. 9, no. 9, pp. 1416, 2020.
- [28] X. Qu and C. G. Kang, "An effective interference alignment approach for device-to-device communication underlying multi-cell interference network," in *IEEE Int. Conf. on ICT Convergence*, Jeju, South Korea, pp. 219–220, 2012.
- [29] H. E. Elkotby, K. F. Elsayed and M. H. Ismail, "Exploiting interference alignment for sum rate enhancement in D2D-enabled cellular networks," in *IEEE Wireless Communications and Networking Conf.*, Shanghai, China, pp. 1624–1629, 2012.
- [30] S. Wonjae, H. J. Kyung and H. H. Choi, "Device-to-device communication assisted interference mitigation for next generation cellular networks," in *IEEE Int. Conf. on Consumer Electronics*, Las Vegas, USA, pp. 623–624, 2013.
- [31] M. M. Alhasani, Q. N. Nguyen, G.-I. Ohta and T. Sato, "A novel four single-sideband M-QAM modulation scheme using a shadow equalizer for MIMO system toward 5G communications," *Sensors*, vol. 19, no. 8, pp. 1944, 2019.
- [32] J. Jiang, M. Peng, W. Wang and K. Zhang, "Energy efficiency optimization based on interference alignment for device-to-device mimo downlink underlying cellular network," in *IEEE Global Communications Conf.*, Atlanta, USA, pp. 585–590, 2013.

- [33] L. Yang, W. Zhang and S. Jin, "Interference alignment in device-to-device LAN underlaying cellular networks," *IEEE Transactions on Wireless Communications*, vol. 14, no. 7, pp. 3715–3723, 2015.
- [34] J. R. Md and L. Lutz, "Robust transceiver optimization for underlay device-to-device communications," in *IEEE Int. Conf. on Communications*, London, UK, pp. 7695–7700, 2015.
- [35] Q. Wang, C. Lai, Y. Dong, Y. Shu and X. Xu, "Joint user clustering and resource allocation for device-to-device communication underlaying mu-mimo cellular networks," *EURASIP Journal on Wireless Communications and Networking*, vol. 15, no. 1, pp. 1–17, 2015.
- [36] M. Aramon *et al.*, "Physics-inspired optimization for quadratic unconstrained problems using a digital annealer," *Frontiers in Physics*, vol. 7, pp. 48, 2019.