

Implementation of High-Q Embedded Band Pass Filter in Wireless Communication

V. Satheesh Kumar^{1,*} and S. Ramesh²

¹Department of Electronics and Communication Engineering, T. J. S Engineering College, Chennai, Tamil Nadu, 601206, India

²Valliammai Engineering College, Chennai, Tamil Nadu, 603203, India

*Corresponding Author: V. Satheesh Kumar. Email: satheeshkumarv.phd@gmail.com

Received: 26 June 2021; Accepted: 18 March 2022

Abstract: At 12.8 MHz center frequency, the advanced miniaturized polymer-based planar high quality factor (Q) passive elements embedded bandpass filter works in the L-band. Because most of the demands operate inside the spectrum, the wideband or high-speed operation necessary to enhance must be acquired in microwave frequency ranges. The channel has a quiet, high-performance micro-filter with wideband rejection. Capacitors and inductors are used in the high quality factor (Q) passive components, and related networks are incorporated in the filter. Embedded layers are concatenated using Three-Dimensional Integrated Circuit (3D-IC) integration, parasitics are removed, and interconnection losses are negotiated using de-embedding methods. A wireless application-based Liquid Crystalline Polymer (LCP) viewpoint is employed as a substrate material in this work. The polymer processes, their properties, and the incorporated high-Q Band Pass Filter Framework. The suggested filter model is computed and manufactured utilizing the L-band frequency spectrum, decreasing total physical length by 31% while increasing bandwidth by 45%.

Keywords: Bandpass filter; wireless communication; frequency spectrum; embedded technology

1 Introduction

Over the last few decades, a wireless communication mechanism has played an essential role in contemporary electronics. The growing reliance on wireless integration and the growing expectation of the communication rapid transit system's capacity to assess it indicates that wireless technologies will continue to grow. It is necessary to get the desired result and free up bandwidth by using new components, circuits, systems, frequency spectrum, and heterogeneous-signal applications. Although smartphone video, voice, and data transmission require an incredibly dense range that comprises Ultra high frequency (UHF), L-band, and S-band, respectively [1]. Additional bandwidth-limited needs continue to change user-oriented, cost-effective items using microwave bands. Because most of the demands operate inside the spectrum, microwave frequency ranges must be achieved to accomplish the high frequency, wideband, or high-speed operation necessary to enhance.



This work is licensed under a Creative Commons Attribution 4.0 International License, which permits unrestricted use, distribution, and reproduction in any medium, provided the original work is properly cited.

The entire edge module for wireless communication techniques results in many functional parts consisting of embedded transceiver circuits, baluns, antennas, power amplifiers, and filters [1]. A balun is a transformer design that makes an unbalanced or signal-ended signal into a balanced signal that can be micro-strip or stripline. The edge module includes the essential filters in regulating the standardized wireless frequency bands and ignores the unnecessary frequency bands. Each wireless device is provided with an Radio Frequency (RF) module containing one or more filters, as displayed in Fig. 1. By applying both the filter integration technique and the design technique, the performance of filters becomes most important for the demand for wireless applications.

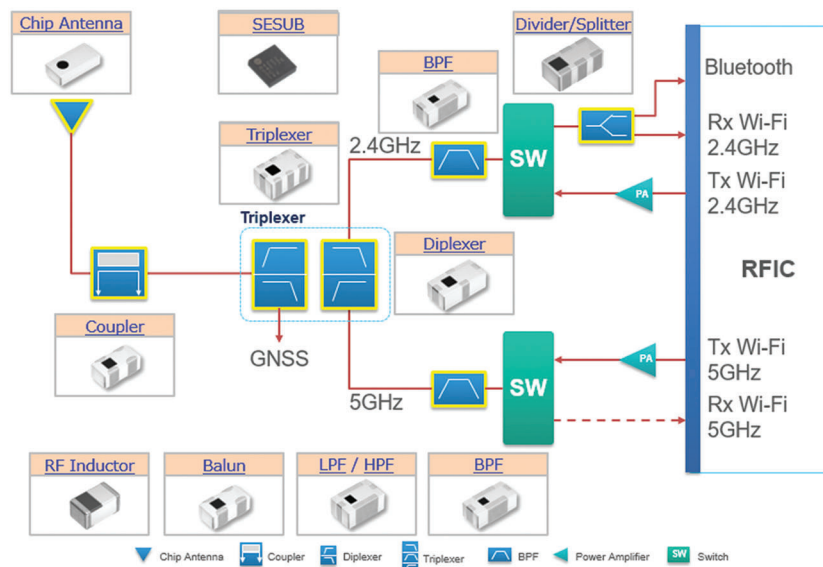

Figure 1: Block diagram of radio frequency circuit module

The design approach increases the filter's performance, even though the filter integration technique influences efficiency. Traditional functional frequency wireless devices come in a bundle with several defined forms and high-level stop-band rejections. Due to in-band insertion loss in both the transmitting and receiving routes, low-power wireless devices for many standardized uses are not very appropriate. The interference from the Wideband Code Division Multiple Access (WCDMA) frequency at 2.17 GHz is reduced by 20 dB, allowing the 230 MHz received from the Wireless Local-Area Network (WLAN) passband to be extended to 2.4 GHz. Therefore, the Bandpass Filter (BPF) based architecture struggles to suppress unwanted frequency signals, pictures, harmonics, and intermediation signals, as well as interference from specified wireless frequency bands. Every electronic device has passive components such as capacitors, filters, and inductors, which take up space in the device while reducing performance. In an electronic device, the electrical components are coordinated with passives, and it has roughly 400 separate passive components whose metal is coupled to a comparable substrate [2,3].

System on-package (SoP) is used in RF, microwave, and other applications to control the packing function. SoP is less expensive and more realistic than system-on-a-chip (SoC) [4]. Digital, RF passives, and on-wafer optical functionalities are all included in the SoC's structure [5]. The multilayer dielectric material is made from the analogue component of SoP space and is attached to the chips either inside or on top of the dielectric packaging material [6]. The SoP element overcomes the constraints of SoC by allowing for a low substrate for RF passives while simultaneously offering room for chip integration on a comparable substrate [7]. The electrical characteristics are connected to a thick multilayer circuit with an

efficiently sealed packing using Low Temperature Co-Fired Ceramic (LTCC), notwithstanding the high cost [8]. The decrease in manufacturing costs is attributable to the Liquid Crystalline Polymer's reel-to-reel processing (LCP). Because the LCP material may be used at different melting temperatures, the multilayer circuit benefits from the two kinds of LCP material. The core layers are made of LCP material with a melting temperature of 315°C, while the bond-ply is made of LCP material with a melting temperature of 290°C. The LTCC structure is realized using a vertically integrated framework. LCP in a microwave circuit substrate is not further treated for practical application. This has been established in microwave applications as a thin-film form since the early 1990s [9–11].

For the heterogeneous System-on-Package (SoP) integration model and the Micro-Electromechanical System (MEMS) structural framework, high-performance efficiency may be obtained with an enhanced quality dielectric facilitated by the liquid crystal polymer (LCP) [12]. system-on-package (SoP) is given system integration *via* a passive embedded approach, which relies on sophisticated manufacturing processes and substrate materials to achieve high-performance efficiency. A wireless application-based LCP viewpoint is employed as a substrate material in this work. Section 2 explains the polymer processes, their accompanying features, and the high-Q embedded Band Pass Filter structure. A high-Q embedded passive polymer substrate is given in Section 3, depending on the 1.625 GHz bandpass. The architecture of a high-Q integrated passive BPF on the LCP substrate with an insertion loss of -3.82 dB at 1.625 GHz is the focus of Section 4. The study work and its accompanying analysis are contrasted in Section 5, and the research effort's conclusion and feature scope are presented in Section 6.

2 Polymer Technology

Printed circuit boards' adequate inner circuit layers do not accept LTCC as a discrete component Printed Circuit Board (PCBs). This harms efficiency and dependability difficulties [13]. Instead of using LTCC procedures, a polymer material called LCP has become famous for its loss reduction and compatibility with PCB production processes.

Up to mm-wave frequencies, the polymer typically has a low dielectric constant of 3 x and a low tangent loss of 0.002. Mechanical flexibility, low coefficient, thermal expansion, and low moisture absorption are the polymer's constructive mechanical properties.

With the realization of high-Q passives, namely LCP, lowly organic materials are enabled in a packaging substrate, allowing for complete integrated wireless applications [14]. LCP material is more suitable for RF applications because it has a low loss and a lower temperature [15].

As a result, the polymer's RF capability and integration capability improved. In comparison to Flame Retardant-4 (FR-4), which serves as the backbone of the integrated system due to its low cost-effectiveness, polymer techniques are harmed by relatively low processing temperatures of 290°C. The results show the fabrication margins due to the misalignment among the various layers, even though it requires a bond-ply material that builds stack-ups.

Low-Noise amplifiers (LNAs), filters, baluns, and Voltage-Controlled Oscillators (VCOs) are all examples of applications that use the characteristics of a single-layer LCP [16]. Significant inductors necessitate high Qs, whereas all concurrent applications necessitate a Qs of at least 50. Because this is a single layer 2D integration, the Qs value is fixed with its horizontal area.

As a result of the reduced linewidth, Qs are slowed down in the process. As shown in Fig. 2, an integrated, standardised mixture module can accommodate a growing demand for voice communication while also being used for other applications such as multimedia and Global Positioning System (GPS). The most effective method, in this case, is 3 Dimensional (3D) integration. Fig. 3 depicts a cross-section of an LCP based on a 3D integration substrate with identical functionalities in both horizontal and vertical directions.

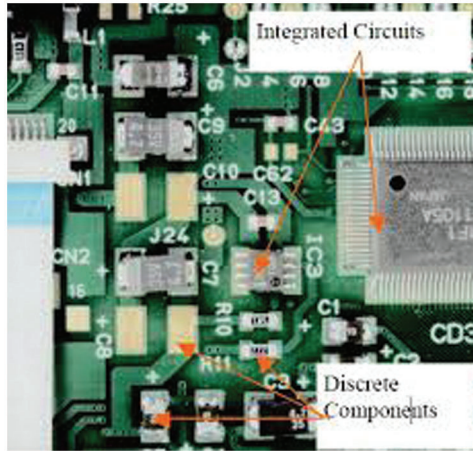

Figure 2: Comparison of discrete vs. integrated elements

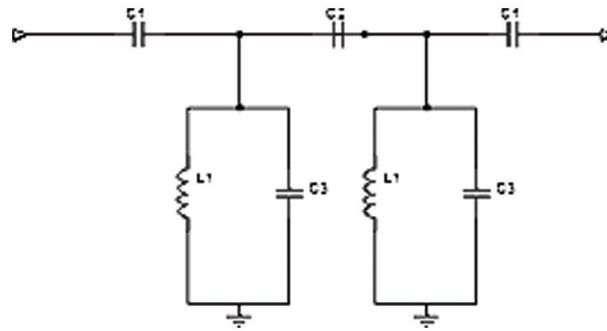

Figure 3: Conventional capacitive-coupled topology

The box containing the various components in the vertex module shown in Fig. 1 is classified into different types included in the RF and baseband modules. As a result, a multilayer 3D design substrate with vertical integration is even more critical. The edge of the system module ignores portable devices with a squashed size. 3D LCP is essentially meeting demand because of its lower integration cost [17–19].

A single, three, and balanced configuration are obtained from the LCP technology. An LCP cross-section with three layers is shown in Fig. 4. An LCP with three layers is linked by a lower melt adhesive. Tangent glass-reinforced organic material with low loss linked with the 25 μm thick LCP dielectric results in a multilayer stack-up. In this process, 4–10 metal layer laminates have been fabricated. The LCP layer has a dielectric constant of 2.9 and a loss tangent of 0.002 [20].

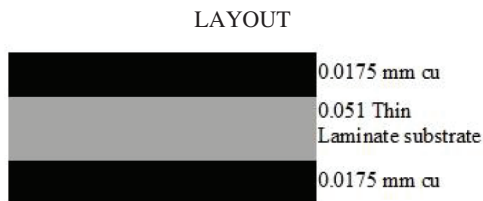

Figure 4: LCP substrate’s Three-layer cross-section

A loss tangent of 0.0035 and a dielectric constant of 3.38 is included in the adhesive layers. The surface mount components utilize the cross-sectional metal layer incorporated with the high Q (>100) inductors. The micro-strip ground layer utilizes the bottom metal. The facility to form micro-vias in the stack-up provides increased component density along with increased routing density. Individual Multilayer Liquid Crystal Polymer (M-LCP) layers are etched independently and then put together before drilling holes [21]. With distinct LTCC, sufficient bonding between metallization and LCP substrates is challenging to achieve. Therefore, adhesive layers are usually engaged between different LCP films. This paper compares LCP and DuPont polymer design and simulation with the High-Q Band Pass Filter.

3 Design of Bandpass Filter

The LCP material and BPFs planned schematic circuit is framed to achieve the corresponding performance efficiency, as shown in Fig. 3. First, the individual lumped elements are measured using traditional microwave design equations.

The inductor, which includes filters, matching networks, and amplifiers, is the essential component in RF systems. In-circuit design, its performance is the most important. High-Q inductors are required for bandpass filters and matching networks. When fabricated with inductors, LCP or M-LCP has extremely high Qs. The spiral inductors with inductances on several nHs are more effective in performance. A Sonnet Electromagnetic (EM) solver was used to simulate a microstrip spiral inductor, as shown in Figs. 5 and 6. The parameters in the lumped circuit model are acquired at a specific frequency.



Figure 5: (a) & (b) Bandpass filter designed and its layout

Matching networks, oscillator tanks, and DC blocks that rely on the capacitor for an effective building block are examples of RF elements and microwave systems. Vertical interdigitated (VID) capacitors frame the miniature capacitor in M-LCP. The multilayer LCP substrate is used to create a spiral metal strip for the inductor and parallel plates for the capacitor, and a spiral metal strip is used to realize the lumped parameters as shown in Figs. 5 and 6.

While acquiring all the lumped-element values, each element is exchanged with the corresponding layout. The LCP technique is implemented to realize the physical layout, as shown in Fig. 5. The conventional second-order capacitive-coupled topology is as shown in Tab. 1.

Design equations for calculating the component values of the capacitively coupled filters can be derived by using standard filter synthesis procedures [22]. Although calculating the component values, the fractional bandwidth of the passband and admittance inverter can be defined as

$$\Delta = \frac{f_2 - f_1}{f_0} \quad (1)$$

$$f_0 = \sqrt{f_1 * f_2} \quad (2)$$

$$J_{01} = \frac{1}{Z_0} \sqrt{\frac{\Pi * \Delta}{4 * g_n}} \quad (3)$$

f_1 and f_2 represent the pass-band edges, f_0 is the centre frequency, g_n is either Butterworth or Chebyshev constants, and Z_0 is the characteristic impedance.

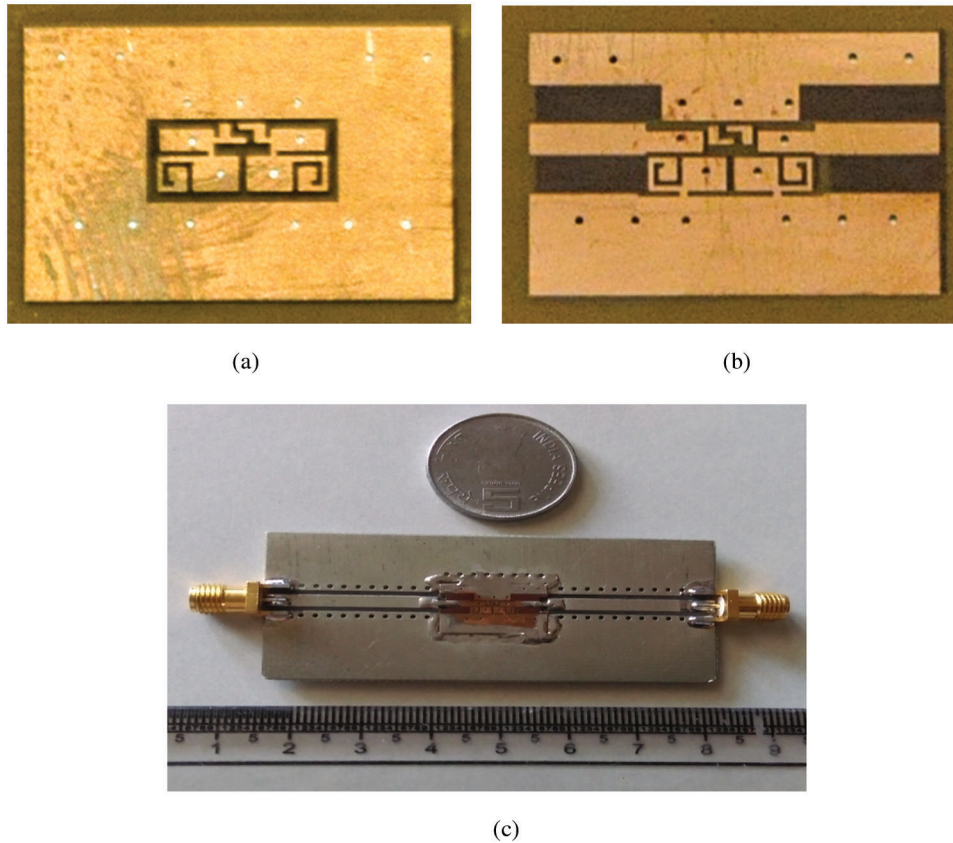

Figure 6: (a), (b) & (c) Layout of the fabricated bandpass filter

Table 1: Table caption

L1	C1	C2	C3
9 nH	0.3 pF	0.2379 pF	0.3 Pf

The L1 inductor's selection initiates the synthesis. The L1's inductance value is chosen to maximise the quality factor that is realizable based on the fabrication and substrate technique. The LCP methodology has made the inductor's quality factor range from 70 to 150 for 1–5 GHz [23]. Then, the values of capacitance are calculated using

$$C_1 = \frac{J_{01}}{\omega_0 \sqrt{1 - (z_0 - J_{01})^2}} \quad (4)$$

$$C_2 = \frac{\Delta}{8 * f_0 * Z_0 \sqrt{g_1 * g_2}} \quad (5)$$

$$C_3 = \frac{1}{L_1 * \omega_0^2} - \frac{C_1}{1 + (\omega_0 * C_1 * Z_0)^2} - C_2 \quad (6)$$

The filter was simulated using Sonnet simulation software. The component design is performed using the balanced Liquid Crystalline Polymer's two-layer technique. [Tab. 2](#) represents the technique of the balanced LCP process technique's cross-section. Core 1 is a 0.0175 mm thick copper core, and Core 2 is a 0.051 mm thick laminate substrate.

Table 2: Properties of the material

Material	Dielectric constant	Loss tangent	Thickness in mm
Polymer	3.41	0.0101	0.051
Liquid crystalline polymer	2.951	0.0021	0.051

The liquid crystalline polymer's configuration and the page of the cross section's thin edge mean different layers of the LCP are distributed over the passives to minimize undesired couplings. Two LCP layers are placed closely together to produce large inductors. The losses due to radiation are minimized using the single environment of the stripline design. These features help make the technology more efficient and suitable for the design of filters [24]. Compared to conventional and narrowband filters, good rejection capacity and a compact size are achieved [25,26].

4 Results Discussion

[Figs. 7a](#) and [7b](#) show the responsive changes as a function of BPF frequency (b). The main goal of the design was to use the L Band as the center frequency of the bandpass filter, as shown in the diagram. At 1.59 GHz, the simulation's S11 parameter is 22.83 dB, while the measurement is 18.68 dB. The simulation's S12 parameter is -0.25 dB at 1.59 GHz, while the measurement is -3.82 dB at 1.625 GHz. According to the design, a bandpass filter for L-band applications is fabricated on LCP material with a cut-off frequency of 1.625 GHz. At 1.625 GHz, we measured loss due to inertia of -3.82 dB, loss while returning of -18.68 dB, bandwidths of 12.8 MHz, and a Q value of 126.9 dB in this design. For the resonant frequency of 1.625 GHz, we got a Q value of 126.9 and a bandwidth of 12.8 MHz, significantly better. The expression below is used to calculate Q's value.

$$Q = \text{Resonant frequency} / \text{bandwidth}. \quad (7)$$

The simulation was performed for two different materials with the same design. The dielectric constant has a slight change in its value. This changes the value of the resonant frequencies. [Figs. 8a](#) and [8b](#) shown below compare the fabrication BPF's S-parameters and the simulation results. This showed an improved result compared to measured and simulated S-parameters shown in [Tab. 3](#).

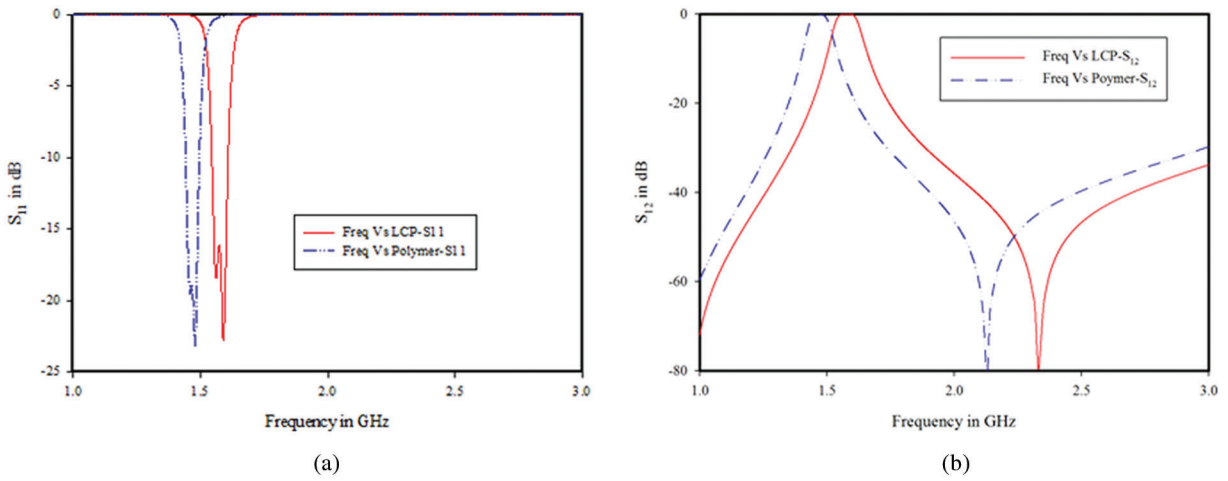

Figure 7: (a) & (b) Simulation comparison between Polymer and LCP (a) S11 (b) S12

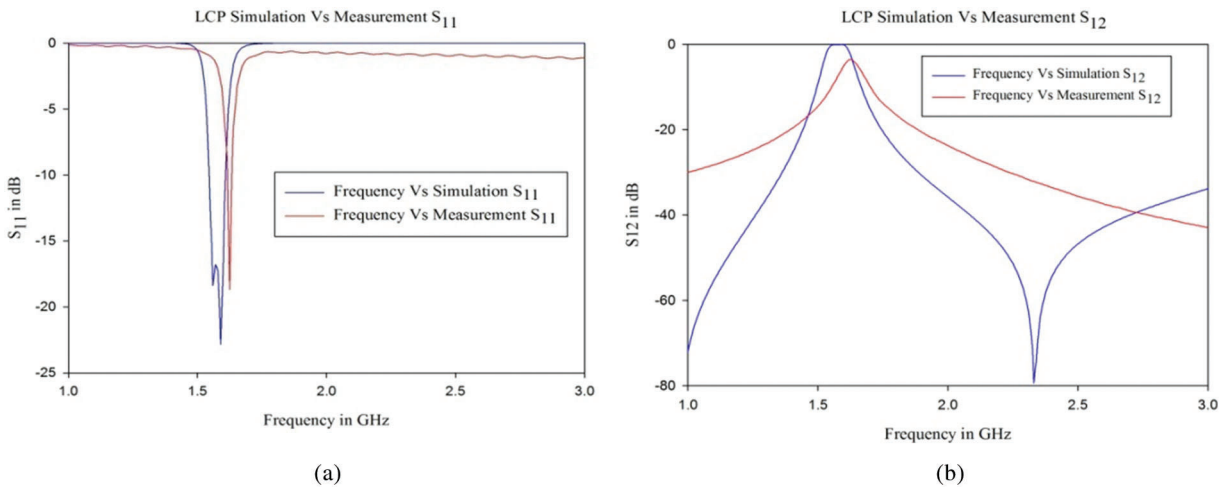

Figure 8: (a) & (b) Comparison between LCP Simulation and Measurement (a) S11 (b) S12

Table 3: Performance comparing the simulation

Material	Loss due to inertia	Bandwidth	Loss due to return
Polymer	1dB 1.45 to 1.51 GHz	6.1 MHz	-22 dB
Liquid crystalline polymer	-3.82dB 1.625 GHz	12.8 MHz	-18.68 dB

The result showed a minimum deviation between the measured and simulated values. This deviation is due to Ground-Signal-Ground (G-S-G) probing discontinuities and discontinuity intolerance of fabrication.

5 Conclusion

First, the Band Pass Filter for L-band operational frequency is designed using classical microwave equations in this paper. For the computation of the lumped components, the equations are used. After completing the computation of the component of lumped elements, the LCP polymer and substrate are

replaced. Every element is rearranged into its proper position. When the frequency is 1.62 GHz, the proposed design measures the loss due to inertia -3.8 dB. The loss of return is measured at -18.6 dB when the frequency is the same. The design was successful, with a Q value of 126.2 and a bandwidth of 12.6 MHz. The high Q-value of passive components makes it possible to achieve low inertia loss without increasing the component's size. Filters based on polymers achieve high band rejection low loss due to inertia, size compactness, and narrow band. The same filter is used to make the LCP substrate. The simulation's parameter "S" is compared to the results obtained by measuring. The result revealed that the measured and simulated values had a minimum deviation. G-S-G probing discontinuities and discontinuity intolerance in fabrication blame this deviation.

Acknowledgement: The authors wish to acknowledge DST-FIST supporting facilities available in the department of Electronics and Communication Engineering, SRM Valliammai Engineering College, Chennai, Tamil Nadu, India.

Funding Statement: The authors received no specific funding for this study.

Conflicts of Interest: The authors declare that they have no conflicts of interest to report regarding the present study.

References

- [1] S. M. El-Ghazaly, V. Nair and S. Goodnick, "Recent trends and enabling technologies in RF and microwave applications," in *Proc. of Asia-Pacific Microwave Conf. 2001*, Taipei, Taiwan, pp. 23–32, 2001.
- [2] R. R. Tummala, "Moore's law meets its match (system-on-package)," *IEEE Spectrum*, vol. 43, no. 6, pp. 44–49, 2006.
- [3] B. Xinha, G. Hongyan, Z. Li, K. H. Tan and C. M. La, "Fabrication and measurement of BPF using IPD technology," in *15th Int. Conf. on Electronic Packaging Technology*, Chengdu, China, 2014.
- [4] S. Pinel, M. Davis, V. Sundaram, K. Lim, J. Laskar *et al.*, "High Q passives on liquid crystal polymer substrates and mBGA technology for 3D integrated RF front-end module," *IEICE Transactions on Electronics*, vol. E86-C, no. 8, pp. 1584–1592, 2003.
- [5] A. Matsuzawa, "RF-SoC—expectations and required conditions," *IEEE Transactions on Microwave Theory and Technology*, vol. 50, no. 1, pp. 245–253, 2002.
- [6] K. Lim, S. Pinel, M. F. Davis, A. Sutono, C-H. Lee *et al.*, "RF-SOP for wireless communications," *IEEE Microwave Magazine*, vol. 3, pp. 88–99, 2002.
- [7] D. C. Thompson, G. E. Ponchak, M. M. Tentzeris and J. Papapolymerou, "Characterization of liquid crystal polymer (LCP) material and transmission lines on LCP substrates from 30 to 110 GHz," *IEEE Transactions on Microwave Theory and Techniques*, vol. 52, no. 4, pp. 1–12, 2004.
- [8] P. Suresh, K. Aanandhasaravanan, C. Iwendi, E. Ibeke and G. Srivastava, "An artificial intelligence-based quorum system for the improvement of the lifespan of sensor networks," *IEEE Sensors Journal*, vol. 21, no. 15, pp. 1–13, 2021.
- [9] K. Jayaraj, T. E. Noll and D. R. Singh, "RF characterization of low-cost multichip packaging technology for monolithic microwave and millimeter-wave integrated circuits," in *URSI Int. Signals, Systems, and Electronics Symp.*, San Francisco, CA, USA, pp. 443–446, 1995.
- [10] E. C. Culbertson, "A new laminate material for high-performance PCBs: Liquid crystal polymer copper-clad films," in *IEEE Electronic Components and Technology Conf.*, Las Vegas, NV, USA, pp. 520–523, 1995.
- [11] K. Jayaraj, T. E. Noll and D. R. Singh, "A low-cost multichip packaging technology for monolithic microwave integrated circuits," *IEEE Transactions on Antennas Propagation*, vol. 43, no. 9, pp. 992–997, 1995.
- [12] S. Sarkar, G. Wang and M. Tentzeris, "RF and mm-wave SOP module platform using LCP and RF MEMS technologies," in *IEEE MTT-S Int. Microwave Symp. Digest*, Fort Worth, TX, USA, pp. 1–12, 2004.
- [13] S. Dalmia, V. Sundaram, G. White and M. Swaminathan, "Liquid crystalline polymer based lumped-element bandpass filters for multiple wireless applications," in *Proc. of IEEE MTT-S Int. Microwave Symp.*, Fort Worth, TX, USA, 2004.

- [14] S. Dalmia, V. Sundaram, G. White and M. Swaminathan, "Liquid crystalline polymer-based RF/wireless components for multi-band applications," in *Proc. of IEEE Electronics Computer Technology Conf. (ECTC)*, Las Vegas, NV, USA, pp. 1866–1873, 2004.
- [15] V. Govind, S. Dalmia, V. Sundaram, G. White and M. Swaminathan, "Design of Multiband Balun on Liquid crystalline polymer (LCP) based Substrates," in *Proc. of IEEE Electronics Computer Technology Conf. (ECTC)*, Las Vegas, NV, USA, pp. 1–14, 2004.
- [16] S. Dalmia, A. Bavisi, S. Mukherjee, V. Govind, G. White *et al.*, "A multiple frequency signal generator for 802.11a/b/g VoWLAN type applications using organic packaging technology," in *Proc. of IEEE Electron. Computer Technology Conf.*, Las Vegas, NV, USA, pp. 1–16, 2004.
- [17] C.-M. Tsai, H. M. Lee and C. C. Tsai, "Planar filter design with fully controllable second passband," *IEEE Transactions on Microwave Theory and Technology*, vol. 53, no. 11, pp. 3429–3439, 2005.
- [18] Y. Qiu, L. Xia and L. Yang, "A compact bandpass filter using multilayer liquid crystal polymer substrate technology," in *IEEE Int. Conf. on Communication Problem-Solving (ICCP)*, Nanjing, China, 2015.
- [19] Y. Lan, Y. Xu, T. Mei, Y. Wu and R. Xu, "A 2~18 Ghz compact microwave bandpass filter suitable for planar and three-dimension flexible integration," in *46th European Microwave Conf.*, London, UK, 2016.
- [20] M. Keramat and R. Kielbasa, "Yield optimization of electronic circuits via improved cg algorithm," in *IEEE Int. Midwest Symp. on Circuits and Systems*, Sacramento, CA, USA, 1997.
- [21] W. Yun, V. Sundaram and M. Swaminathan, "High-Q embedded passives on large panel multilayer liquid crystalline polymer-based substrate," *IEEE Transactions on Advanced Packaging*, vol. 30, no. 3, pp. 580–591, 2007.
- [22] A. Bavisi, M. Swaminathan and E. Mina, "Liquid crystal polymer-based planar lumped component dual-band filters for dual-band WLAN systems," in *IEEE, Radio and Wireless Symp.*, Long Beach, CA, USA, 2007.
- [23] P. Suresh, U. Saravanakumar, C. Iwendi, S. Mohan and G. Srivastav, "Field-programmable gate arrays with low power vision system using dynamic switching," *Computers & Electrical Engineering*, vol. 90, no. 5, pp. 1–18, 2021.
- [24] D. Athreya, V. Sundaram, M. Iyer and R. Tummala, "Ultra-high Q embedded inductors in a highly miniaturized family of low loss organic substrates," in *IEEE Electronics and Communication Technology Conf.*, Lake Buena Vista, FL, USA, pp. 2073–2080, 2008.
- [25] L. Hepburn and J. Hong, "Compact integrated lumped element LCP filter," *IEEE Microwave and Wireless Components Letters*, vol. 26, no. 1, pp. 19–21, 2016.
- [26] R. Hosono, Y. Uemichi, Y. Hasegawa, Y. Nakatani, K. Kobayashi *et al.*, "Development of millimeter-wave devices based on liquid crystal polymer substrate," *IEICE Electronics Express*, vol. 14, no. 20, pp. 1–13, 2017.