

On the Some Particularities of the Torsional Wave Dispersion in a Finitely Pre-Deformed Hollow Sandwich Cylinder

Surkay D. Akbarov^{1,2}, Tamer Kepceler¹ and M. Mert Egilmez¹

Abstract: This paper develops the investigations started in a work by Akbarov, Kepceler and Mert Egilmez (2011) and studies the some particularities of the torsional wave dispersion in a finitely pre-deformed sandwich hollow cylinder. The mentioned particularities relate to the influence of the stiffness ratio of the core and face layers' materials and the influence of the thickness ratio of these layers on the dispersion character of the wave under consideration. Moreover, the mentioned influences are studied for the various values of the parameter which characterizes the initial strains in the cylinder's layers. The mechanical relations of the materials of the cylinders are described through the harmonic potential. The analytical expression is presented for the low wave number limit values of the torsional wave propagation velocity. The numerical results on the foregoing influences are presented and discussed.

Keywords: finite initial strains, wave dispersion, three-layered hollow cylinder, high elastic material, torsional wave.

1 Introduction

The review of the related investigation was made in the paper by Akbarov, Kepceler and Mert Egilmez (2011) in which the study by Öztürk and Akbarov (2008, 2009a, 2009b), Kepceler (2010) and Cilli and Öztürk (2010) is continued for the three-layered sandwich hollow cylinder made from the high elastic materials. However, in the paper by Akbarov, Kepceler and Mert Egilmez (2011) concrete numerical results were presented and discussed for the case where the material of the core layer is stiffer than the materials of the face layers. At the same time, there are also

¹ Corresponding author. Yildiz Technical University, Faculty of Mechanical Engineering, Department of Mechanical Engineering, Yildiz Campus, 34349, Besiktas, Istanbul-Turkey. akbarov@yildiz.edu.tr

² Institute of Mathematics and Mechanics of National Academy of Sciences of Azerbaijan, 37041, Baku, Azerbaijan.

many real cases where the materials of the face layers are stiffer than the material of the core layer. Therefore in the present paper the investigations in Akbarov, Kepceler and Mert Egilmez (2011) is developed namely for the noted above case.

Investigations carried out by utilizing the Three-dimensional Theory of Elastic Waves in Initially Stressed Bodies (TLTEWISB within the scope of the piecewise homogeneous body model. It is assumed that in each component of the sandwich hollow cylinder there exists only the homogenous normal stress acting on the areas which are perpendicular to the lying direction of the cylinders. The mechanical relations of the materials of the cylinders are described through the harmonic potential.

Note that the related problem for the bi-layered hollow cylinder was investigated in a paper by Akbarov, Kepceler, Mert Egilmez and Dikmen (2011).

2 Formulation of the problem

We consider the sandwich hollow circular cylinder shown in Fig. 1 and assume that in the natural state the radius of the internal circle of the inner hollow cylinder is R and the thickness of the inner, middle and outer cylinders are $h^{(1)}$, $h^{(2)}$ and $h^{(3)}$, respectively. In the natural state we determine the position of the points of the cylinders by the Lagrangian coordinates in the cylindrical system of coordinates $Or\theta z$. The values related to the inner, middle and external hollow cylinders will be denoted by the upper indices (1), (2) and (3), respectively. Furthermore, we denote the values related to the initial state by an additional upper index 0.

It is assumed that the cylinders have infinite length in the direction of the Oz axis and the initial strain-stress state in each component of the considered body is axisymmetric with respect to this axis and is also homogeneous. Moreover, it is assumed that the mentioned initial strain-stress states in the inner, middle and external hollow cylinders are determined through the following displacement fields:

$$u_r^{(k),0} = (\lambda_1^{(k)} - 1)r, \quad u_\theta^{(k),0} = 0, \quad u_z^{(k),0} = (\lambda_3^{(k)} - 1)z, \quad \lambda_1^{(k)} \neq \lambda_3^{(k)}, \quad k = 1, 2, 3, \quad (1)$$

where $u_r^{(k),0}$ ($u_z^{(k),0}$) is the displacement along the radial direction (along the direction of the Oz axis) and $\lambda_1^{(k)}$ ($\lambda_3^{(k)}$) are the elongation parameters.

Such an initial stress field may be present with stretching or compression of the considered body along the Oz axis. The stretching or compression may be conducted for the inner, middle and the external hollow cylinders separately before they are compounded. However, the results, which will be discussed below, can also be related to the case where the inner, middle and external hollow cylinders

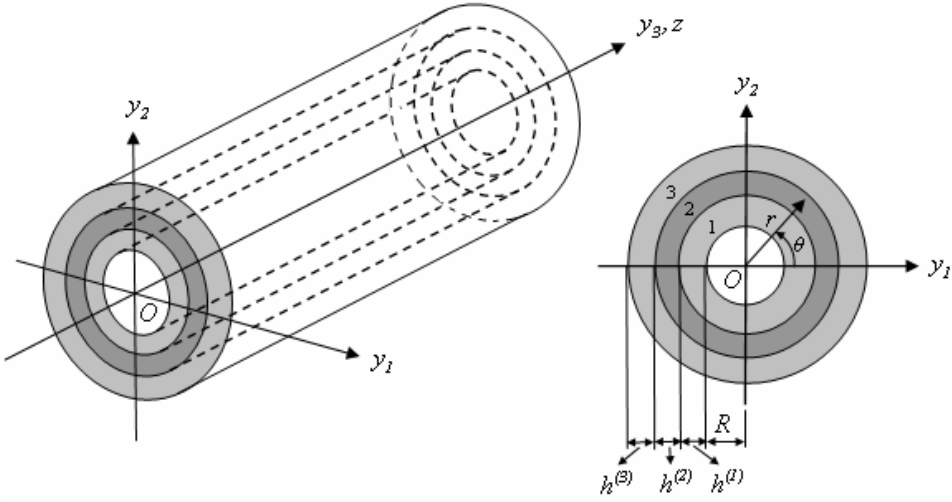

Figure 1: The geometry of the three-layered hollow cylinder.

are stretched or compressed together after the compounding. In this case, as a result of the difference of the radial and circumferential deformations of the inner, middle and external cylinders' materials (similar to the deformations in the classical linear theory of elasticity which are determined through Poisson's coefficient), inhomogeneous initial stresses acting on the areas which are parallel to the Oz axis may arise. Nevertheless, according to the well known mechanical consideration, the aforementioned inhomogeneous initial stresses can be neglected under corresponding investigations, in the cases where these stresses are less significant than those acting on the areas which are perpendicular to the Oz axis. Otherwise, it is necessary to take the mentioned inhomogeneous stresses into account, which may be a subject of other investigations. Consequently, in the present investigation we assume that only the normal stress (denoted by $s_{zz}^{(k),0}$) acting on the areas which are perpendicular to the Oz axis, is different from zero.

For the initial state of the cylinders, we associate the Lagrangian cylindrical system of coordinates $O'r'\theta'z'$ and introduce the following notation:

$$r' = \lambda_1^{(k)} r, \quad z' = \lambda_3^{(k)} z, \quad R' = \lambda_1^{(1)} R, \quad (2)$$

$$k = 1 \text{ for } R \leq r \leq R + h^{(1)}, \quad k = 2 \text{ for } R + h^{(1)} < r \leq R + h^{(1)} + h^{(2)}, \quad k = 3 \text{ for } R + h^{(1)} + h^{(2)} < r \leq R + h^{(1)} + h^{(2)} + h^{(3)}.$$

The values related to the system of coordinates associated with the initial state below, i.e. with $O'r'\theta'z'$, will be denoted by an upper prime.

Within this framework, let us investigate the axisymmetric torsional wave propagation along the $O'z'$ axis in the considered body. We do this investigation by using the coordinates r' and z' in the framework of the TLTEWISB. We will follow the style and notation used in the paper Akbarov, Kepceler and Mert Egilmez (2011) and in the monograph by Guz (2004). According to this paper, the mentioned investigation is reduced to the following eigen-value problem.

The equations of motion are:

$$\frac{\partial}{\partial r'} Q'_{r'\theta}{}^{(k)} + \frac{\partial}{\partial z'} Q'_{\theta z}{}^{(k)} + \frac{1}{r'} \left(Q'_{r'\theta}{}^{(k)} + Q'_{\theta r'}{}^{(k)} \right) = \rho'^{(k)} \frac{\partial^2}{\partial t^2} u'_{\theta}{}^{(k)}. \quad (3)$$

The elasticity relations are:

$$\begin{aligned} Q'_{z'\theta}{}^{(k)} &= \omega'_{1331}{}^{(k)} \frac{\partial u'_{\theta}{}^{(k)}}{\partial z'}, & Q'_{r'\theta}{}^{(k)} &= \omega'_{1221}{}^{(k)} \frac{\partial u'_{\theta}{}^{(k)}}{\partial r'} - \omega'_{1212}{}^{(k)} \frac{u'_{\theta}{}^{(k)}}{r'}, \\ Q'_{\theta r'}{}^{(k)} &= \omega'_{2121}{}^{(k)} \frac{\partial u'_{\theta}{}^{(k)}}{\partial r'} - \omega'_{2112}{}^{(k)} \frac{u'_{\theta}{}^{(k)}}{r'}. \end{aligned} \quad (4)$$

In (3) and (4) through $Q'_{\theta r'}$, $Q'_{r'\theta}$, and $Q'_{z'\theta}$, perturbation of the components of the non symmetric Kirchhoff stress tensor are denoted. The notation $u'_{\theta}{}^{(k)}$ shows the perturbations of the components of the displacement vector. $\rho'^{(k)}$ is the density of the k -th material. The constants $\omega'_{2121}{}^{(k)}$, $\omega'_{1221}{}^{(k)}$, $\omega'_{2112}{}^{(k)}$, $\omega'_{1212}{}^{(k)}$ and $\omega'_{1331}{}^{(k)}$ in (4) are determined through the following expressions.

$$\begin{aligned} \omega'_{2121}{}^{(k)} &= \omega'_{1221}{}^{(k)} = \omega'_{2112}{}^{(k)} = \omega'_{1212}{}^{(k)} = \frac{\mu^{(k)}}{\lambda_3^{(k)}} \omega'_{1331}{}^{(k)} = \frac{\lambda_1^{(k)}}{\lambda_1^{(k)} + \lambda_3^{(k)}} 2\mu^{(k)} \lambda_1^{(k)} + \frac{1}{\lambda_3^{(k)}} S_{33}^{(k),0}. \\ s_{zz}^{(k),0} &= \left[\lambda^{(k)} \left(2\lambda_1^{(k)} + \lambda_3^{(k)} - 3 \right) + 2\mu^{(k)} \left(\lambda_3^{(k)} - 1 \right) \right] \left(\lambda_3^{(k)} \right)^{-1}. \end{aligned} \quad (5)$$

Thus, torsional wave propagation in the sandwich hollow cylinder will be investigated by the use of the equations (3), (4) and (5). In this case we will assume that the following complete contact and boundary conditions are satisfied:

$$\begin{aligned} Q'_{r\theta}{}^{(1)} \Big|_{r'=\lambda_1^{(1)}R} &= 0, & u'_{\theta}{}^{(1)} \Big|_{r'=\lambda_1^{(1)}R(1+h^{(1)}/R)} &= u'_{\theta}{}^{(2)} \Big|_{r'=\lambda_1^{(1)}R(1+h^{(1)}/R)} \\ Q'_{r\theta}{}^{(1)} \Big|_{r'=\lambda_1^{(1)}R(1+h^{(1)}/R)} &= Q'_{r\theta}{}^{(2)} \Big|_{r'=\lambda_1^{(1)}R(1+h^{(1)}/R)}, \\ Q'_{r\theta}{}^{(2)} \Big|_{r'=\lambda_1^{(1)}R(1+h^{(1)}/R)+\lambda_1^{(2)}h^{(2)}} &= Q'_{r\theta}{}^{(3)} \Big|_{r'=\lambda_1^{(1)}R(1+h^{(1)}/R)+\lambda_1^{(2)}h^{(2)}}, \end{aligned}$$

$$u'_{\theta}{}^{(2)} \Big|_{r'=\lambda_1^{(1)}R(1+h^{(1)}/R)+\lambda_1^{(2)}h^{(2)}} = u'_{\theta}{}^{(3)} \Big|_{r'=\lambda_1^{(1)}R(1+h^{(1)}/R)+\lambda_1^{(2)}h^{(2)}},$$

$$Q'_{r\theta}{}^{(3)} \Big|_{r'=\lambda_1^{(1)}R(1+h^{(1)}/R)+\lambda_1^{(2)}h^{(2)}+\lambda_1^{(3)}h^{(3)}} = 0. \quad (6)$$

Note that in the case where the initial strains are absent in the constituents in the cylinder, i.e. in the case where $\lambda_1^{(k)} = \lambda_3^{(k)} = 1.0$, the foregoing formulation coincides with the corresponding one proposed within the scope of the classical linear theory of elastodynamics.

3 Solution procedure and obtaining the dispersion relation

For solution of the equations (3) and (4) we use the following presentation:

$$u'_{\theta}{}^{(m)}(r', z', t) = -\frac{\partial}{\partial r'} \Psi^{(m)}(r', z', t) \quad (7)$$

where the function $\Psi^{(m)}$ in (7) satisfies the equation written below:

$$\left[\Delta' + \left(\xi'^{(m)} \right)^2 \frac{\partial^2}{\partial z'^2} - \frac{\rho'}{\omega'_{1221}} \frac{\partial^2}{\partial t^2} \right] \Psi = 0, \quad (8)$$

where

$$\Delta' = \frac{d^2}{dr'^2} + \frac{1}{r'} \frac{d}{dr'}, \quad \left(\xi'^{(m)} \right)^2 = \frac{2 \left(\lambda_3^{(m)} \right)^3}{\left(\lambda_1^{(m)} \right)^2 \left(\lambda_1^{(m)} + \lambda_3^{(m)} \right)}. \quad (9)$$

It follows from the problem statement that the presentation:

$$\Psi^{(m)}(r', z', t) = \psi^{(m)}(r') \exp(i(kz' - \omega t)) \quad (10)$$

holds. Thus, we obtain from (8) and (10) the following equation for the unknown function, $\psi^{(m)}(r')$:

$$\left[\frac{d^2}{dr'^2} + \frac{1}{r'} \frac{d}{dr'} - \left(k^2 \left(\xi'_1{}^{(m)} \right)^2 - \frac{\rho'^{(m)} \omega^2}{\omega'_{1221}} \right) \right] \psi^{(m)}(r') = 0. \quad (11)$$

Introducing the notation:

$$\left(s^{(m)} \right)^2 = \left(k^2 \left(\xi'_1{}^{(m)} \right)^2 - \frac{\rho'^{(m)} \omega^2}{\omega'_{1221}} \right). \quad (12)$$

The solution to the equation (11) can be written as follows:

$$\begin{aligned}\psi^{(m)}(r') &= A^{(m)}J_0\left(s^{(m)}kr'\right) + B^{(m)}Y_0\left(s^{(m)}kr'\right) \text{ if } \left(s^{(m)}\right)^2 > 0 \quad m = 1, 2, 3 \\ \psi^{(m)}(r') &= A^{(m)}I_0\left(s^{(m)}kr'\right) + B^{(m)}K_0\left(s^{(m)}kr'\right), \text{ if } \left(s^{(m)}\right)^2 < 0\end{aligned}\quad (13)$$

Using the equations (11), (13), (10), (5) and (4) we obtain the following dispersion equation for the condition (6):

$$\det\|\alpha_{ij}\| = 0, \quad i, j = 1, 2, 3, 4, 5, 6, \quad (14)$$

The expressions of α_{ij} are given in the paper by Akbarov, Kepceler and Mert Egilmez (2011).

4 Numerical Results and Discussions

It follows from the expressions (2) and (5) that the initial stress-strain state in each constituent of the sandwich cylinder is determined through the parameters $\lambda_3^{(k)}$ and $\lambda^{(k)}/\mu^{(k)}$. Consequently, if we assume that the foregoing initial stress-strain state in the sandwich plate appears after compounding of the inner, middle and outer cylinders and the condition:

$$\lambda_3^{(1)} = \lambda_3^{(2)} = \lambda_3^{(3)}, \quad \lambda^{(1)}/\mu^{(1)} = \lambda^{(2)}/\mu^{(2)} = \lambda^{(3)}/\mu^{(3)} = 1.5 \quad (15)$$

takes place, then it is obtained that $\lambda_1^{(1)} = \lambda_1^{(2)} = \lambda_1^{(3)}$. In other words, for the case where relation (15) takes place, then the initial stress-strain state determined by equations (2) and (5) is satisfied exactly. This statement verifies the reality of the considered initial stress-strain state in the sandwich hollow cylinder.

Consider the dispersion relation $c = c(kR)$ where $c (= \omega/k)$ is the wave propagation velocity, k is the wave number, ω is the frequency and R is the inner radius of the inner cylinder (Fig. 1) obtained from a numerical solution of the dispersion equation (14). For simplification of the discussions below we introduce the following notation:

$$c_{20}^{(m)} = \sqrt{\frac{\mu^{(m)}}{\rho^{(m)}}}, \quad c_2^{(m)} = c_2^{(m)}\left(\lambda_3^{(m)}\right) = c_{20}^{(m)} \left[\frac{2\lambda_3^{(m)}}{(\lambda_2^{(m)})^3 \lambda_1^{(m)} (\lambda_3^{(m)} + \lambda_2^{(m)})} \right]^{\frac{1}{2}} \quad (16)$$

Note that the expression for $c_2^{(m)}\left(\lambda_3^{(m)}\right)$ in (16) is obtained from the following relation:

$$c_2^{(m)}\left(\lambda_3^{(m)}\right) = \left[\frac{(\xi^{(m)})^2 \omega_{1221}^{(m)}}{\rho^{(m)}} \right]^{\frac{1}{2}}, \quad (17)$$

where $\omega'_{1221}^{(m)}$ and $(\xi'_{1}^{(m)})^2$ are determined through the equations (5) and (9) respectively.

Now we consider the limit values of the torsional wave propagation velocity.

Low wave number limit values as $kR \rightarrow 0$. As usual, to obtain this limit value, each term of the corresponding dispersion equation is expanded into series form for small values of $kR \rightarrow 0$ and only the limit values of the wave propagation velocity are taken into account. For the considered problem, by using power series expansions of the Bessel functions, retaining only the dominant term at $kR \rightarrow 0$ and doing the corresponding mathematical manipulations to calculate the determinant in equation (14) we obtain the following limit value for the torsional wave propagation velocity for the low wave number limit:

$$\frac{c}{c_{20}^{(1)}} = \left[\frac{\frac{\mu^{(1)}}{\lambda_2^{(1)}} (\xi'_{1}^{(1)})^2 + \frac{\mu^{(2)}}{\lambda_2^{(2)}} \alpha (\xi'_{1}^{(2)})^2 + \frac{\mu^{(3)}}{\lambda_2^{(3)}} \beta (\xi'_{1}^{(3)})^2}{\mu^{(1)} + \mu^{(2)} \alpha \left(\frac{c_2^{(1)}}{c_2^{(2)}}\right)^2 + \mu^{(3)} \beta \left(\frac{c_2^{(1)}}{c_2^{(3)}}\right)^2} \right]^{\frac{1}{2}}, \quad (18)$$

Where

$$\alpha = \frac{(\lambda_2^{(2)})^4 (\eta^{(2)})^4 - (\lambda_2^{(1)})^4 (\eta^{(1)})^4}{(\lambda_2^{(1)})^4 ((\eta^{(1)})^4 - 1)}, \quad \beta = \frac{(\lambda_2^{(3)})^4 (\eta^{(3)})^4 - (\lambda_2^{(2)})^4 (\eta^{(2)})^4}{(\lambda_2^{(1)})^4 ((\eta^{(1)})^4 - 1)}.$$

$$\eta^{(1)} = 1 + \frac{h^{(1)}}{R}, \quad \eta^{(2)} = 1 + \frac{h^{(1)}}{R} + \frac{\lambda_1^{(2)} h^{(2)}}{\lambda_1^{(1)} R}, \quad \eta^{(3)} = 1 + \frac{h^{(1)}}{R} + \frac{\lambda_1^{(2)} h^{(2)}}{\lambda_1^{(1)} R} + \frac{\lambda_1^{(3)} h^{(3)}}{\lambda_1^{(1)} R}. \quad (19)$$

In the case where $\mu^{(3)} = 0$ the expression (19) transforms to the corresponding asymptotic expression given below for the bi-layered finitely pre-strained hollow cylinder:

$$\frac{c}{c_{20}^{(1)}} = \left[\frac{\frac{\mu^{(1)}}{\lambda_2^{(1)}} (\xi'_{1}^{(1)})^2 + \frac{\mu^{(2)}}{\lambda_2^{(2)}} \alpha (\xi'_{1}^{(2)})^2}{\mu^{(1)} + \mu^{(2)} \alpha \left(\frac{c_2^{(1)}}{c_2^{(2)}}\right)^2} \right]^{\frac{1}{2}}. \quad (20)$$

In the case where $\lambda_3^{(k)} = \lambda_1^{(k)} = 1.0$ ($k = 1, 2$), i.e. in the case where the initial strains are absent in the bi-layered cylinder, the expression (20) transforms to the

following one:

$$\frac{c}{c_{20}^{(1)}} = \left[\frac{\mu^{(1)} + \mu^{(2)} \alpha_1}{\mu^{(1)} + \mu^{(2)} \alpha_1 \left(\frac{c_2^{(1)}}{c_2^{(2)}} \right)^2} \right]^{\frac{1}{2}} \quad (21)$$

where $\alpha_1 = \alpha|_{\lambda_1^{(2)}=\lambda_1^{(1)}=1.0}$.

Note that the expression (21) coincides with the corresponding one obtained in the paper Armenakas (1971). Moreover, note that the asymptotic expression (18) is the generalization for the finite initial strain state of the corresponding one obtained in paper by Ozturk and Akbarov (2008). It needs to be remembered that in the paper by Ozturk and Akbarov (2008) the aforementioned expression is obtained for the case where the initial strains are small and determined within the scope of the classical linear theory of elasticity.

At the same time, in the case where $\lambda_3^{(k)} = \lambda_1^{(k)} = 1.0$ ($k = 1, 2, 3$), i.e. in the case where the initial strains are absent in the layers of the considered three-layered (sandwich) hollow cylinder, the asymptotic expression (18) transforms to the corresponding one obtained within the scope of the classical linear theory of elastodynamics. Consequently, the expression (18) is also a new one for the classical linear theory of elastodynamics.

High wave number limit values as $kR \rightarrow \infty$. Asymptotic analyses of the dispersion equations (14) show that the high limit value of the torsional wave propagation velocity, i.e. the limit velocity as $kR \rightarrow \infty$ is equal to $\min \left\{ c_2^{(1)} \left(\lambda_3^{(1)} \right); c_2^{(2)} \left(\lambda_3^{(2)} \right); c_2^{(3)} \left(\lambda_3^{(3)} \right) \right\}$ and in turn, the following relation holds:

$$c \rightarrow \min \left\{ c_2^{(1)} \left(\lambda_3^{(1)} \right); c_2^{(2)} \left(\lambda_3^{(2)} \right); c_2^{(3)} \left(\lambda_3^{(3)} \right) \right\} \text{ as } kR \rightarrow \infty. \quad (22)$$

The values of $c_2^{(k)} \left(\lambda_3^{(k)} \right)$ ($k = 1, 2, 3$) are determined by the expression (17). Note that the relation (22) is also confirmed by well-known physical-mechanical considerations.

Numerical results obtained by the numerical solution to the dispersion equation (14). This solution is found by employing the “bi-section method” algorithm using the PC. We attempt to verify the numerical algorithm used and the corresponding programs. To the best knowledge of the authors, no suitable numerical results have been obtained for torsional wave propagation (dispersion) in a three-layered hollow cylinder with which we can compare the numerical results obtained from the

solution to the dispersion equation (14). In general, there are only a few investigations, such as in papers by Markus and Mead (1995) and Kudlicka (2004) in which the torsional wave propagation in the three-layered composite cylinder is studied within the scope of the classical linear theory of elastodynamics. Moreover, in papers by Markus and Mead (1995) and Kudlicka (2004) it was assumed that the materials of the skin layers are orthotropic and that the material of the core layer is isotropic. We can not verify the algorithm used in the present paper with the results given in the papers by Markus and Mead (1995) and Kudlicka (2004) because in the present investigation we assume that the materials of the layers of the cylinder are isotropic. Therefore, we verify the algorithm used in the present paper with the results obtained in the paper by Armenakas (1971). Note that in the paper by Armenakas (1971), the torsional wave propagation in a bi-layered hollow cylinder was studied within the scope of the linear theory of elastodynamics.

At first, we suppose that $\mu^{(3)} = \mu^{(2)}$ and attempt to compare the results obtained from the solution to the dispersion equation (14) with the corresponding results given in the paper by Armenakas (1971). As in the paper by Armenakas (1971) we assume that $\mu^{(1)}/\mu^{(2)} = 1$, $\rho^{(2)}/\rho^{(1)} = 0.5$, $h^{(1)}/R = 0.2$ and $(h^{(2)} + h^{(3)})/R = 0.2$ and consider the dependence between $\omega h^{(2)}/(\pi c_{20}^{(2)})$ and $2h^{(2)}/\Lambda$, where Λ is the wavelength. Note that in the paper by Armenakas (1971) instead of the notation $(h^{(2)} + h^{(3)})/R (= 0.2)$, the notation $h^{(2)}/R (= 0.2)$ is used. Thus, within the framework of the foregoing assumptions we consider the dispersion curves obtained from the solution to the dispersion equation (29) for various values of the elongation parameter $\lambda_3 (= \lambda_3^{(1)} = \lambda_3^{(2)} = \lambda_3^{(3)})$. The curves for the lowest three modes are given in Fig. 2 from which it follows that the results obtained in the case where $\lambda_3 = 1$ (i.e. where the initial strains are absent in the constituents of the cylinder) coincide with the corresponding ones given in the paper by Armenakas (1971). At the same time, it can be seen from Fig. 2 that, in general, the initial stretching (compression) of the compounded bi-material hollow cylinder causes an increase (a decrease) in the torsional wave propagation velocity. This conclusion holds strongly for the first mode. But for the second and third modes the foregoing conclusion is violated for the cases where $kR \rightarrow 0$. Consequently, there exists such values of kR before (after) which the initial stretching (compression) of the cylinder causes a decrease (an increase) in the velocity of the torsional wave propagation in the bi-layered hollow cylinder. This statement will also be discussed below for the three-layered cylinder.

The results discussed above indicate that the analytical and numerical solution methods used in the present investigation are correct. Now we consider the numerical results regarding the dependence between $c/c_{20}^{(2)}$ and kR obtained for the

sandwich cylinder. We consider the case where $h^{(1)} = h^{(3)}$, $\rho^{(1)} = \rho^{(3)}$, $\rho^{(2)}/\rho^{(1)} = \rho^{(2)}/\rho^{(3)} = 1$, $\mu^{(1)} = \mu^{(3)}$ and $\mu^{(2)} > \mu^{(1)} (= \mu^{(3)})$. Unless otherwise specified, we will also assume that $\lambda^{(1)}/\mu^{(1)} = \lambda^{(2)}/\mu^{(2)} = \lambda^{(3)}/\mu^{(3)} = 1.5$.

Consider graphs given in Fig. 3 which show dispersion curves constructed for various $\mu^{(2)}/\mu^{(1)}$ under $\lambda_3 = 1$, $h^{(1)}/R = h^{(3)}/R = 0.1$, $h^{(2)}/R = 0.4$. In this figure the graphs given under $\mu^{(2)}/\mu^{(1)} \leq 1$ are also given in the paper Akbarov, Kepceler and Mert Egilmez (2011). It follows from these graphs that the torsional wave propagation velocity increase with the stiffness of the face layers of the cylinder.

Fig. 4 shows the dispersion curves obtained for the first lowest mode in the cases where $\mu^{(2)}/\mu^{(1)} = \mu^{(2)}/\mu^{(3)} = 0.5$ (solid lines) and 2 (dashed lines) for various values of the parameter λ_3 under $h^{(1)}/R = h^{(3)}/R = 0.1$, $h^{(2)}/R = 0.4$. Note that the case where $\mu^{(2)}/\mu^{(1)} = 2$ was also considered in the paper by Akbarov, Kepceler and Mert Egilmez (2011). It follows from these results that the initial stretching (compression) of the layers of the cylinder causes an increase (a decrease) in the torsional wave propagation velocity. Direct verification of the data shows that the results given in Fig. 4 approach the corresponding values of $c/c_{20}^{(2)}$ calculated by the expression (18) as $kR \rightarrow 0$. At the same time, these results show that the values of $c/c_{20}^{(2)}$ approach $c_2^{(1)}(\lambda_3) (= c_2^{(3)}(\lambda_3))$ as determined by the expression (17) as $kR \rightarrow \infty$.

Consider the influence of the thickness of the core layer on the wave dispersion curves. This influence is illustrated by the graphs given in Fig. 5 which are constructed for various $h^{(2)}/R$ under $\mu^{(2)}/\mu^{(1)} = 0.5$ (solid lines) and 2 (dashed lines), $h^{(1)}/R = h^{(3)}/R = 0.1$ and $\lambda_3 = 1.0$. As can be expected, in the case where $\mu^{(2)}/\mu^{(1)} = 0.5$ ($\mu^{(2)}/\mu^{(1)} = 2$) an increase in the values of $h^{(2)}/R$ causes to decrease (to increase) in the values of the torsional wave propagation velocity, i.e. in the values of $c/c_{20}^{(2)}$.

Investigate also dispersion curves related to the second and third modes. These curves are given in Fig 6 for various values of the parameter λ_3 in the case where $\mu^{(2)}/\mu^{(1)} = 0.5$, $h^{(1)}/R = h^{(3)}/R = 0.1$, $h^{(2)}/R = 0.4$.

Note that the corresponding dispersion diagrams are given in Fig. 7. It follows from these graphs that the character of the influence of the initial strains of the layers of the cylinder on the wave propagation velocity in the second and third approximations depends on the wave number parameter kR . In other words, there exists such value of the kR (denoted by $(kR)_*$) before which, i.e. for $kR < (kR)_*$ the initial stretching (compressing) causes to decrease (to increase) of the wave propagation velocity. But in the cases where $kR > (kR)_*$, contrariwise, the initial stretching (compressing) causes to increase (to decrease) of the wave propagation velocity in the second and third modes. Consequently, in the case where $kR = (kR)_*$, the initial

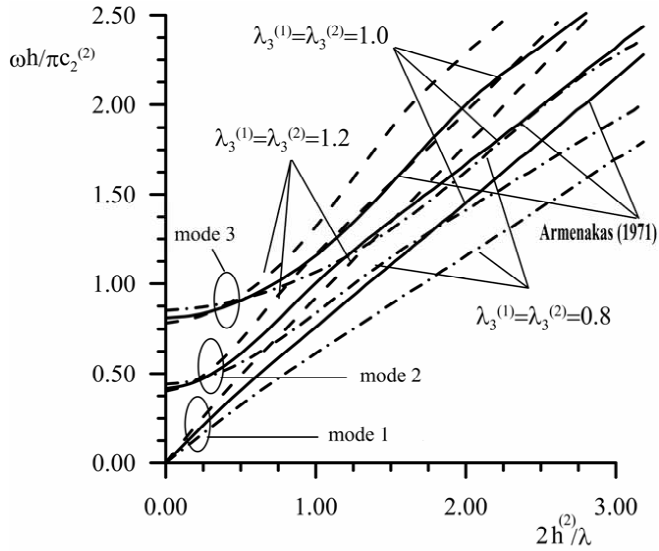

Figure 2: The comparison of the numerical results obtained by applying of the algorithm used in the present paper with the corresponding results obtained in the paper by Armenakas (1971).

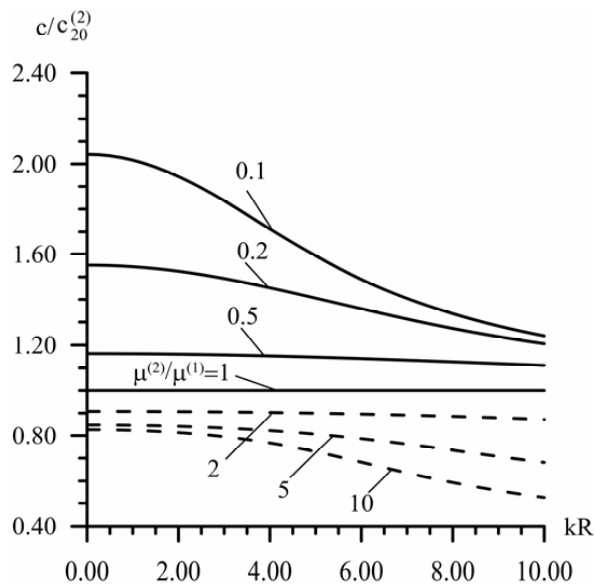

Figure 3: The influence of the ratio $\mu^{(2)}/\mu^{(1)}$ on the dispersion curves of the first mode constructed in the cases where under $h^{(1)}/R = h^{(3)}/R = 0.1$, $h^{(2)}/R = 0.4$ and $\lambda_3 = 1$.

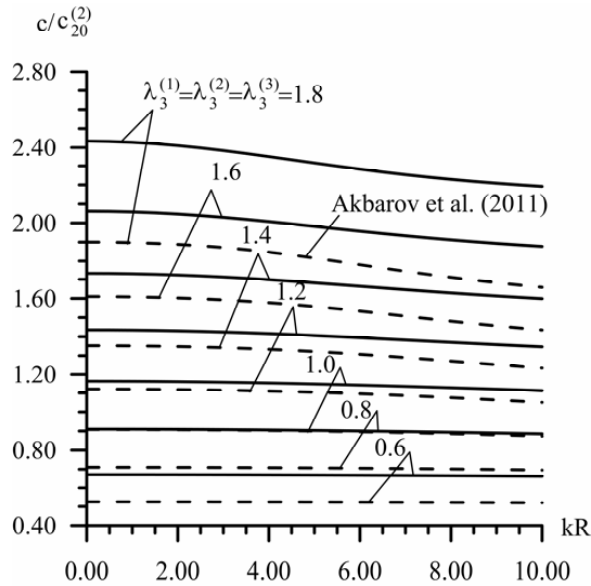

Figure 4: The influence of the initial strains of the layers on the dispersion curves of the first mode constructed in the cases where $\mu^{(2)}/\mu^{(1)} = 0.5$ (solid lines) and $\mu^{(2)}/\mu^{(1)} = 2$ (dashed lines) under $h^{(1)}/R = h^{(3)}/R = 0.1$, $h^{(2)}/R = 0.4$

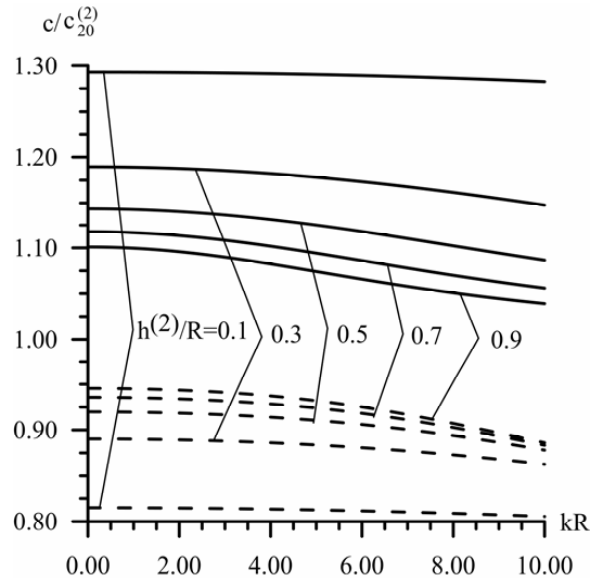

Figure 5: The influence of the thickness of the core layer on the dispersion curves of the first mode in the cases where $\mu^{(2)}/\mu^{(1)} = 0.5$ (solid lines) and $\mu^{(1)}/\mu^{(2)} = 2$ (dashed lines) under $h^{(1)}/R = h^{(3)}/R = 0.1$

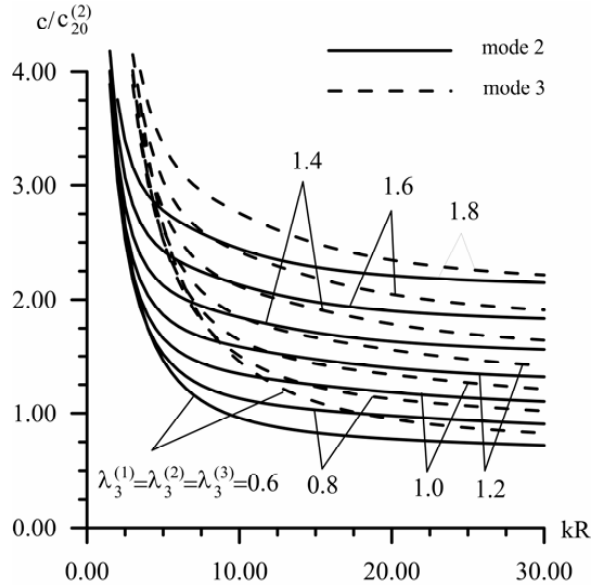

Figure 6: The influence of the initial strains on the dispersion curves of the second and third modes constructed for the cases where $\mu^{(2)}/\mu^{(1)} = \mu^{(2)}/\mu^{(3)} = 0.5$ under $h^{(1)}/R = h^{(3)}/R = 0.1, h^{(2)}/R = 0.4$.

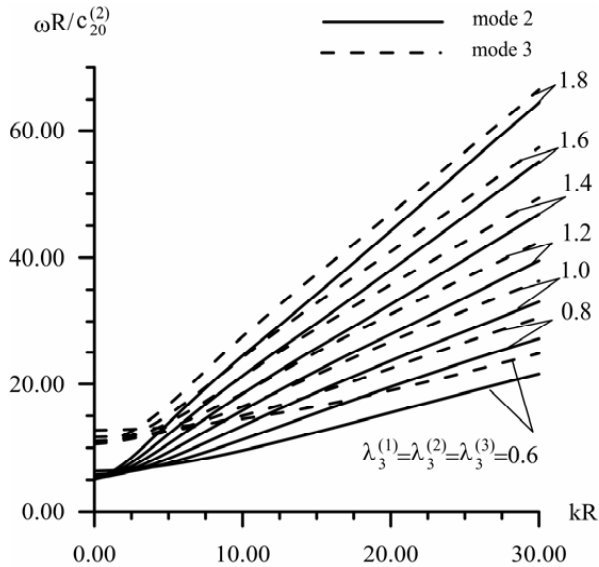

Figure 7: The influence of the initial strains on the dispersion diagrams of the second and third modes constructed for the cases where $\mu^{(2)}/\mu^{(1)} = \mu^{(2)}/\mu^{(3)} = 0.5$ under $h^{(1)}/R = h^{(3)}/R = 0.1, h^{(2)}/R = 0.4$.

strains do not influence on the mentioned wave propagation velocity. However, as follows from the graphs given in Fig. 4, the wave propagation velocity in the first mode increase (decrease) with initial stretching (compressing) of the layers for all considered values of kR .

5 Conclusions

In the present paper, the study started in the paper by Akbarov, Kepceler and Mert Egilmez (2011) is developed for the case where the face layers of the sandwich hollow cylinder is stiffer than that of the core layer. The investigations are made within the scope of the piecewise homogeneous body model with the use of the Three-dimensional Linearized Theory of Elastic Waves in Initially Stressed Bodies. Concrete numerical results are presented basically for the case where the initial strains in the cylinders are equal to each other. According to these results the following concrete conclusions are indicated.

in the first lowest mode the initial stretching (compression) of the layers of the cylinder causes an increase (a decrease) in the torsional wave propagation velocity; in the second and third modes the influence of the initial strains of the cylinder on the torsional wave propagation velocity depends (in the qualitative sense) on the values on the dimensionless wave-number kR . In this case there exists such a value of $kR (= (kR)_*)$ before (after) which the initial stretching causes a decrease (an increase) but the initial compression causes an increase (a decrease) in the velocity of the torsional wave propagation;

under $\lambda_3 < 1$, i.e. under initial compression the values of the cut of frequency of the second and third modes increase with decreasing λ_3 , but under $\lambda_3 > 1$ the noted values of the cut of frequency become less than those obtained in the case where $\lambda_3 = 1$, i.e. where the initial strains are absent in the considered sandwich cylinder; in the case where the face layers' materials are stiffer (core layer's material is stiffer) than that of the core layer (of the face layers) an increase of the thickness of the core layer causes to decrease (to increase) in the values of the torsional wave propagation velocity.

References

Akbarov S.D.; Kepceler T.; Egilmez M.M. (2011): Torsional wave dispersion in a finitely pre-strained hollow sandwich circular cylinder. *Journal of Sound and Vibration*, vol. 330, pp. 4519-4537.

Akbarov S.D.; Kepceler T.; Egilmez M.M.; Dikmen F. (2011): Torsional wave propagation in the finitely pre-stretched hollow bi-material compound circular cylin-

der. *CMC: Computers Materials & Continua*, vol. 26, no.2, pp. 91-109.

Armenakas A. E. (1971): Propagation of harmonic waves in composite circular cylindrical shells.II Numerical investigation. *AIAA J.*, vol. 9, no. 4, pp. 599-605.

Cilli A.; Ozturk A. (2010): Dispersion of torsional waves in initially stressed multilayered circular cylinders. *Mechanics of Composite Materials*, vol. 46, no. 2, pp. 227–236.

Guz A.N. (2004): Elastic waves in the body with initial (residual) stresses. A.S.K., Kiev, (in Russian).

Kepeceler T. (2010): Torsional wave dispersion relations in a pre-stressed bi-material compounded cylinder with an imperfect interface. *Applied Mathematical Modelling*, vol. 34, pp. 4058-4073.

Kudlicka J. (2004): Energy flow of axisymmetric elastic waves in a three-layered transtropic-isotropic-transtropic, composite cylinder. *Journal of Sound and Vibration*, vol. 277, pp. 1093-1100.

Markus S.; Mead D.J. (1995): Wave motion in a three-layered, orthotropic-isotropic-orthotropic, composite shell. *Journal of Sound and Vibration*, vol. 181, pp. 149-167.

Ozturk A.; Akbarov S.D. (2008): Propagation of torsional waves in a pre-stretched compound hollow circular cylinder. *Mechanics of Composite Materials*, vol. 44, no. 1, pp. 77–86.

Ozturk A.; Akbarov S.D. (2009a): Torsional wave propagation in a pre-stressed circular cylinder embedded in a pre-stressed elastic medium. *Applied Mathematical Modelling*, vol. 33, pp. 3636-3649.

Ozturk A.; Akbarov S.D. (2009b): Torsional wave dispersion relations in a pre-stressed bi-material compounded cylinder. *ZAMM – Journal of Applied Mathematics and Mechanics / Z. Angew. Math. Mech.*, vol. 89, no. 9, pp. 754-766.

